

# 5X Max

*Cellular signal booster kit for the home or office*

## User Guide



Congratulations you have purchased the high-performance 5X Max cell phone signal booster that features multiple patented booster technologies which deliver reliable cellular connectivity inside large buildings in the weakest signal areas. Combined, they deliver the strong, fast and reliable performance, which includes faster mobile data, more reliable calls and consistent connectivity for multiple phones and devices on all North America carriers, including Verizon, AT&T and T-Mobile.

If you have any questions during setup, please reach out to our US-based experienced support technicians:

Call: 1-888-365-6283 Email: [support@surecall.com](mailto:support@surecall.com) | Visit: [www.surecall.com/support](http://www.surecall.com/support)



Watch installation, optimization and troubleshooting techniques on our SureCall YouTube channel



[@SureCall](https://twitter.com/SureCall)



Stay up to date with all things SureCall

# TABLE OF CONTENTS

OVERVIEW .....	3
Why indoor signal can be weak .....	3
How it works .....	3
Package contents .....	4
Optional accessories .....	5
BEFORE INSTALLATION .....	6
Important. Before You Begin .....	6
Taking signal measurements with your phone .....	7
Finding your closest cell tower .....	10
Soft install .....	12
Tools needed .....	12
Grounding the outside antenna .....	12
Power requirements .....	12
Routing cable .....	12
INSTALLATION .....	13
Installation overview .....	13
Step 1: Find area outside with strongest signal .....	13
Step 2: Install the outside antenna and outside amplifier .....	14
Step 3: Mount the inside antennas .....	16
Step 4: Place the inside host unit and connect cables .....	18
Step 5: Connect to power .....	19
BOOSTER TESTING AND OPTIMIZATION .....	19
Antenna optimization .....	19
Antenna testing .....	20
LCD INTERFACE .....	21
Conditions defined .....	21
Parameters of RSSI .....	22
Parameters of uplink gain and downlink gain .....	22
Real gain .....	23
MANUAL CONTROLS .....	23
TROUBLESHOOTING .....	24
SPECIFICATIONS .....	25
Kitting .....	26
CONSUMER GUIDELINES .....	27
WARRANTY .....	28
Three-year product warranty .....	28

## OVERVIEW

### Why indoor signal can be weak

There are several obstacles that can contribute to the poor reception you receive in your home:

- Distance to your carrier's cell phone tower
- Obstructions caused by terrain and foliage
- Building materials like low-E glass, metal and concrete

### How it works

1. The high-gain outside antenna captures even the weakest cell signal, from the cell tower where it is aimed.
2. The 5X Max outside booster uses Extended Range Technology™ (ERT) to grab signal outside, at its strongest point, where it boosts voice, text and data signals for all 4G & 5G devices.
3. Using ultra low-loss cable, signal is transmitted from the outside to the 5X Max inside host amplifier.
4. The signal is then broadcast from the inside panel antenna to all cellular devices in range.
5. The 5X Max system also works in reverse, boosting the outgoing signal and to faraway and hard-to-reach towers.

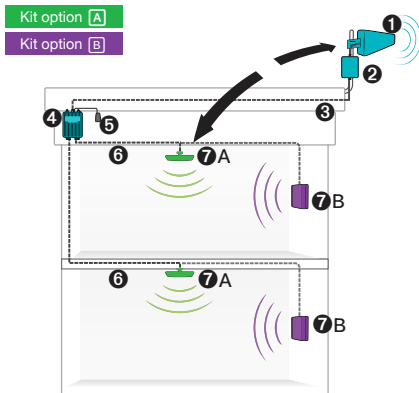

*How the SureCall 5X Max booster works*

## Package contents

Unpack all package contents. For missing or damaged items, contact your reseller.

Turn over the signal booster and record the model and serial number for reference:

Serial #: \_\_\_\_\_

Purchase Date: \_\_\_\_\_

Keep the carton and packing material to store the product in case you need to return.

Model number	Model name	Outside Antenna Type	Outside Cable Length	Inside Antenna		Inside Cable	
				(Qty)	Type	(Qty)	Length
SC-5XMax-Y2U	5X Max Yagi / 2 Ultra-Thin	Yagi	100 ft	(2)	Ultra-Thin	(2)	100 ft
SC-5XMax-Y2P	5X Max Yagi / 2 Panel	Yagi	100 ft	(2)	Panel	(2)	100 ft



*Outside Yagi Antenna:  
(SC-532W)*



*Outside Amplifier*



*Outside Cable  
(100 ft; SC-400)*

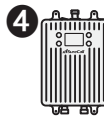

*Inside host amplifier*



*Power supply*



*Inside Cable  
(100 ft; SC-400) (x2)*



*Inside Ultra-Thin Antennas:  
(SC-528W) (x2)*

OR



*Inside Panel Antennas:  
(SC-548W) (x2)*





**WARNING:** Any product modifications that use unauthorized antennas, cables, and/or coupling devices are prohibited by the FCC. Contact FCC for details: 1-888-CALL-FCC. Changes or modifications not expressly approved by SureCall could void the user's authority to operate the equipment.



**WARNING:** Do not collocate antennas or operate the outdoor antenna with any other antenna or signal booster.

## Optional accessories

Looking to upgrade your SureCall booster? Boost your signal even further with these bestselling accessories:

	<p>SC-LP</p>	<p>Lightning arrester prevents damage from electrical surges</p>
	<p>SC-MOUNT-JBAR</p>	<p>Adjustable 20-inch mounting pole for outdoor antenna</p>

## BEFORE INSTALLATION

### IMPORTANT. BEFORE YOU BEGIN.

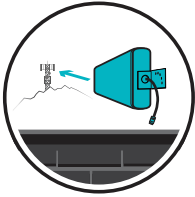

#### IDENTIFY THE AREA OF STRONGEST OUTSIDE SIGNAL.

Since booster performance is largely determined by the signal strength received by your outside antenna, it is important to identify the location of best signal for placement of your antenna.

The best location is generally found on the side of your home that faces your nearest cell tower and as high as possible -- where the antenna can 'see' your cell tower. Better signal received by your outside antenna means better booster performance inside. Conversely, the weaker your outside signal, the more limited your coverage will be indoors.

If you're unsure of the direction of your carrier's closest cell tower, see page 11 on Finding your closest cell tower for suggestions.



#### DO NOT RELY ON CELL PHONE BARS AS AN ACCURATE MEASURING TOOL

Cell phone bars are an approximation of your signal that varies by phone and carrier. Placing your phone in test mode or downloading an app that shows your signal in decibels (dB) is more accurate. For help using this feature on your device, see "Taking signal measurements with your phone" on page 8.

During planning, installation and testing, take multiple readings several minutes apart. Also, verify that you can place and hold a call.

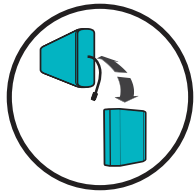

#### BETTER ANTENNA SEPARATION MEANS BETTER PERFORMANCE

Maintain a distance of at least 25 vertical feet or up to 50 feet of horizontal distance, especially if sufficient vertical separation cannot be achieved. Also, make certain the antennas are aimed away from one another.

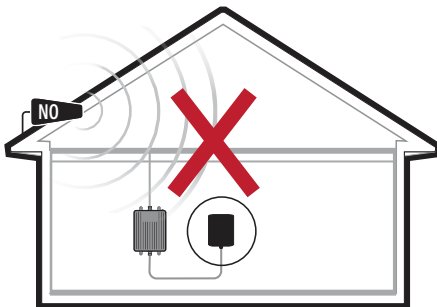

Antenna Placement

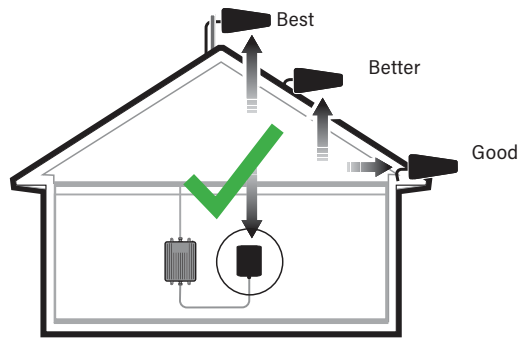

Antenna Aiming

## Taking signal measurements with your phone

Cell phone bars are an approximation of your signal that varies by phone and carrier. Viewing measurements in decibel milliwatts provides a more accurate reading. In most cases, units are reported in RSRP (LTE & 5G signals) and will generally fall between -80 dBm (strong) and -130 dBm (very weak). If you are connected over 3G or HSPA the decibels units are reported in RSSI and the units will generally fall between -50 dBm (strong) and -100 dBm (very weak).

**PLEASE NOTE,** To achieve optimal performance for your booster, it is vital to take care choosing antenna placement and antenna alignment. The coverage area that the booster provides is directly related to the strength of incoming signal received by the outdoor antenna. Mounting the outside antenna where the signal is the strongest provides the best results. If signal is extremely weak where the outside antenna is installed, indoor coverage will be limited.

See the instructions to measure decibels on your phone.

Measuring signal will be helpful to (1) identify the location outside with the strongest signal for placement of your outside antenna and (2) to measure indoor signal strength during installation and testing of your system.

During installation and testing, always take multiple readings several minutes apart. Also, take note of the band number related to each reading for accurate comparisons.

**NOTE**, signal measurements are displayed alongside their measurement scale. RSRP is one scale commonly used, as is RSSI. For more information, see "Signal measurement scales" on page 10.

**FOR IPHONE** dBm signal measurements, use the methods below.

1. First turn off your Wi-Fi
2. Dial \*3001#12345#\* then press the call button.
3. The field test screen will appear. Once open, the menu navigation varies depending on the iOS version.
4. Navigate to "Cell Info" in the menu
5. The measurement that reads "RSRP" is your cellular signal strength in decibel-milliwatts.
6. Note Band number

If you're using an earlier version of iOS or looking for more detailed information, we have more instructions available here: [www.SureCall.com/support](http://www.SureCall.com/support)

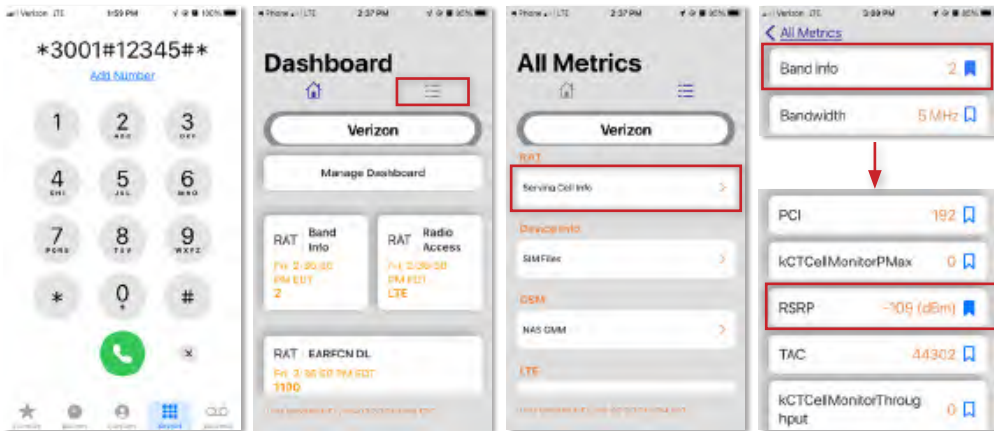

*iPhone test mode*

ENGLISH

**FOR ANDROID** devices: Download the app “LTE Discovery” in the Google Play store.

1. Note band number
2. 4G LTE/5G (measurement in RSSI or RSRP)



Android app “LTE Discovery”

### Signal measurement scales

The relationship between RSRP and RSSI is approximate and depends on the channel bandwidth, noise floor and channel loading. The chart below displays the approximate equivalent of all four measurements:

	Signal Power (dBm)		Signal Quality (dB)	
	RSRP Phone in LTE	RSSI Phone in HSPA	RSRQ Phone in LTE	SINR Phone in HSPA
<b>Very Edge</b>	-125	-102	-25	3
<b>Average</b>	-110	-85	-20	10
<b>Good</b>	-95	-70	-12	15
<b>Best</b>	-80	-55	-8	20

## Finding your closest cell tower

Since performance is largely determined by the signal received by the outdoor antenna, it is important to know the direction in which you will aim your directional outside antenna before installation.

The best location for your outside antenna is generally found on the side facing your nearest cell tower and as high as possible -- where the antenna can 'see' your cell tower.

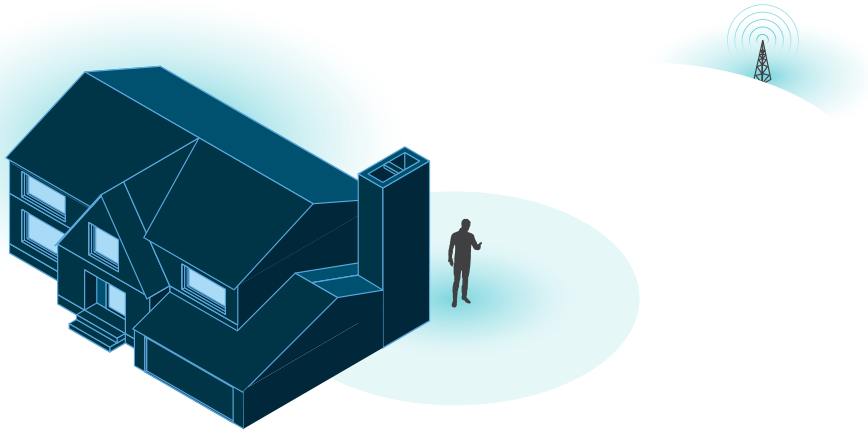

*Finding your strongest outside signal*

If you're not sure of the location of your nearest cell tower, there are resources available. You may utilize crowd-sourced cell tower resources such as sites like [www.cellmapper.net](http://www.cellmapper.net)

See below for brief instructions on utilizing cellmapper.net



**WARNING:** Do not collocate antennas or operate the outdoor antenna with any other antenna or signal booster.

Visit website [www.cellmapper.net](http://www.cellmapper.net)

1. Find your location on the map
2. Select your provider

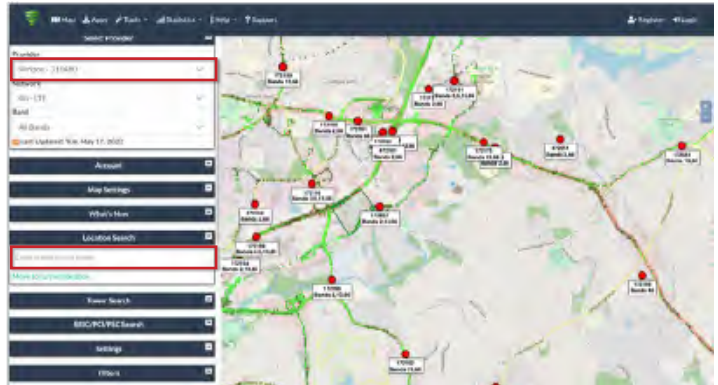

3. Find your cell tower by clicking on the red or green dots on the map closest to your home.

Once selected, detailed information of each base station is shown to the left, including the communication standards and frequency band and block.

The shaded area represents the coverage area for that base station.

4. Locate the closest base station with signal coverage facing the direction of your home and note the direction in relation to your home.

Note: While your home may or may not be located inside a shaded coverage zone indicated on the map.

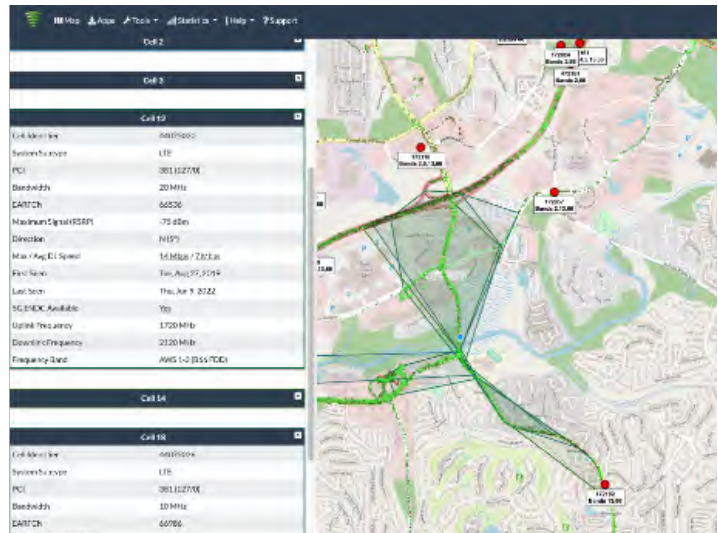

## Soft install

Prior to securing the location of any booster components, a "soft install" is recommended as adjustments may be needed to optimize performance.

Refrain from securing your cable, drilling any holes, etc. until you complete and test the installation of the system.

## Tools needed

- Ladder
- Drill
- 1 to 2 inch diameter pole for mounting outside antenna (if needed, SC-MOUNT-JBAR can be purchased separately)
- Recommended: Surge protected power strip and cable clips

## Grounding the outside antenna

SureCall recommends all outside antennas be properly grounded. See "Optional accessories" on page 6.

## Power requirements

This booster uses 12v input voltage (power supply part: SC-AC-12V3.8A-B). DO NOT use the booster with a higher or lower voltage power supply. This can damage the booster, cause personal injury, and void your warranty.

Use of a power strip with surge protection is strongly recommended.

## Routing cable

SureCall recommends that cable connected to the outside antenna run straight down and away from the outside antenna, not wrapped or draped near it. When securing the cable, be sure to remove any kinks or loops.

Route cable along and through a wall that leads closest to the location of the booster.

SureCall recommends that cable entering the home from an exterior wall use appropriately rated sealant/caulking at the point of entry.

Following completion of install, SureCall recommends weatherproofing the exterior coax connections with sealing tape.

## INSTALLATION

Before installation, review all the information in this manual.

Prior to securing the location of any booster parts, a "soft install" is recommended as adjustments may be needed to optimize performance.

### Installation overview

Step 1. Find the outside area with the strongest signal.

Step 2. Install the outside antenna **1** and the outside amplifier **2**, **3** in the area identified in step 1.

Step 3. Install the Inside antennas **7**, **6**

Step 4. Place the inside host unit **4** and connect cables

Step 5. Connect power **5** and turn on.

Check System and Optimize Installation.

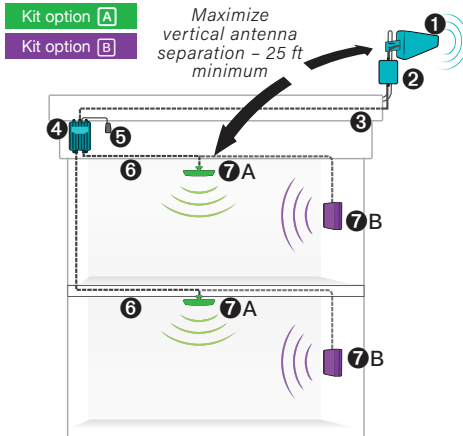

Installation overview

### Step 1: Find area outside with strongest signal

Identify the outside location with the strongest signal for placement of your outdoor antenna. Maximum performance is achieved when the antenna is aimed toward the strongest signal source. If you know the direction of your provider's tower, point the antenna in that direction. If you are unsure of the location, see "Finding your closest cell tower" on page 11.

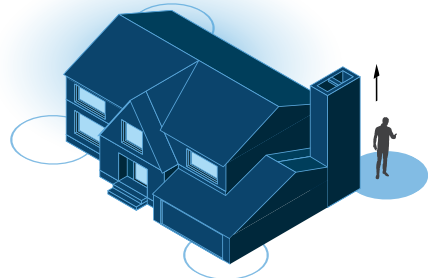

Finding your strongest outside signal

## Step 2: Install the outside antenna and outside amplifier

Once you have identified the area of strongest signal, choose where you will mount your outside antenna and outside amplifier while considering the following antenna placement guidelines.

Note there are two main outside components -- a Yagi directional antenna and SureCall outside amplifier.



Outside Yagi antenna and mounting bracket



5X Max outside amp and mounting bracket



Outside Cable (100 ft)

- Mount at the highest possible location above the roofline – The mounting area must have at least a 3 ft radius clear of obstructions, other radiating elements and metal objects such as pipes or metal siding.
- Maximize antenna separation. Plan at least 25 vertical feet (or at least 50 horizontal feet) of separation between the outside and inside antennas.
- Note that both components should be mounted to an exterior surface or a 1-2" diameter pole. A mounting pole is available separately (SC-MOUNT-JBAR). PVC piping from your local hardware can also be used.
- Avoid placement near windows, where possible, as it increases the potential for oscillation.
- Ensure the outside antenna is oriented to face away from the inside antenna.
- Mount the outside antenna at the corner or side of the roof which faces your cell tower.
- Avoid placing / aiming the antenna towards materials (such as windows) where the signal may be reflected towards your home.

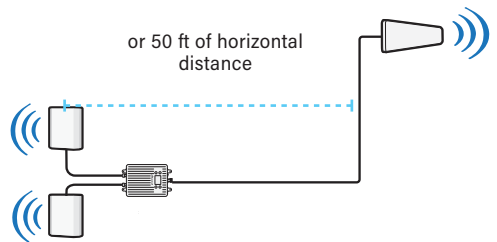
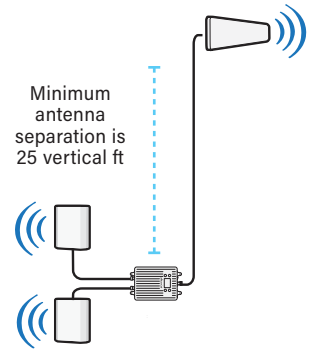

Maximize antenna separation

### 1 Install Yagi antenna

Once you have identified your install location, assemble the u-bolt, bracket, nuts and washers onto a pole (available separately) as shown in the illustration.

Orient the antenna with the drip hole at the bottom.

### 2 Place the outside amplifier

Next assemble the bracket for the outside amplifier the same way you did the yagi bracket and secure in the same location within range of the antenna cable connection.

### 3 Connect cable to the outside amplifier, as shown

With both components in place, connect one end of the provided 100 ft. coax cable to the outside amplifier and hand tighten the connection.

Do not fix mounting hardware until the optimum antenna angle is found. Loosely secure the antenna in a manner that allows for rotation during final system testing.

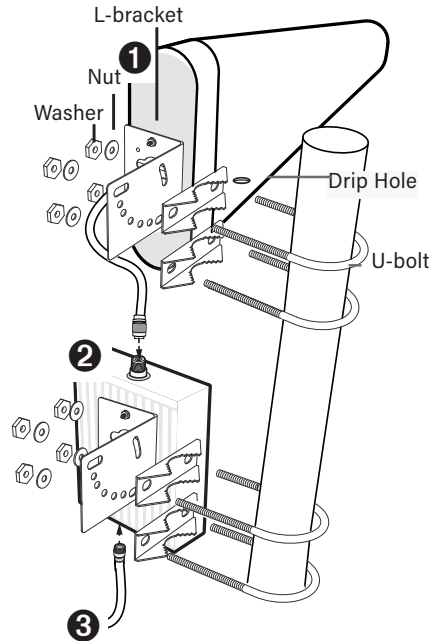

*Outside system assembly*

## Step 3: Mount the inside antennas

7a



Inside Omni-Directional UltraThin antennas (x2)

7b



Inside Directional Panel antennas (x2)

6



Inside cable; SC-400, 100 ft. (x2)

5



4



Inside host amp and power supply

Your kit includes a set of two inside antennas -- Either Omni-directional UltraThin ceiling-mount antennas or Directional wall-mount panel antennas.

Both kits include a set of indoor cables that are used to connect the antennas to the inside host unit.

The range of antenna is dependent on three factors:

- Physical obstructions
- Power generated by booster
- Signal level received by the outdoor antenna

For kit A with omni-directional antennas:

- Optimal placement should be central to where signal is needed with minimal obstacles near the antennas.
- SureCall's UltraThin dome antenna is mounted to the ceiling and broadcasts in 360°.

For kit B with directional panel antennas:

- Antennas should be mounted to a wall facing the area signal is needed – SureCall's panel antenna broadcasts in a 120° beamwidth.

Choose a location for your inside antennas while considering the following general guidelines:

- Maximize isolation between the outside antenna and inside antennas (minimum 25 ft vertical separation or 50 ft of horizontal separation).
- The performance of your antennas is limited by building materials between the antenna and your mobile device. The antenna may be concealed behind a wall provided there are no materials that could obstruct signals.
- Orient the inside antennas so they aim away from the outdoor antenna.



Face inside antenna away from outside antenna

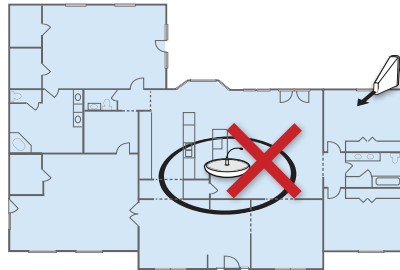

DO NOT face outside antenna towards the inside antenna



DO NOT face inside antenna towards the outside antenna

## UltraThin antenna installation

The SC-528W wideband antenna is an omni-directional interior antenna that gathers and sends signals from all sides. Besides the antenna itself, parts include mounting options for an install that is accessible by crawl space or one that is not. Optimally, It should be located central to where signal is needed with minimal obstacles.

### For each antenna:

If accessible by crawl space:

1. Drill a 20 mm diameter hole in the ceiling. The size should be large enough to allow the antenna's plastic cable base to pass through.
2. Place antenna cable through hole.
3. From crawl space, screw the fixing nut onto antenna

If not accessible by crawl space, a metal bracket mount has been provided along with instructions for this mounting option.

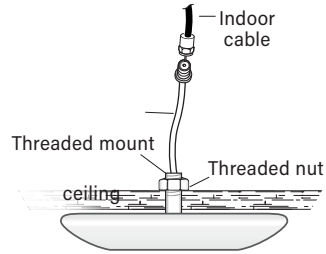

*UltraThin-antenna installation*

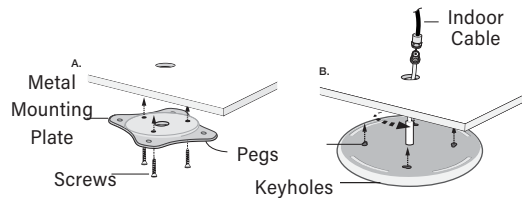

*UltraThin antenna installation, mounting option 2*

## Panel antenna installation

Besides the antenna itself, parts include mounting equipment for a flat horizontal surface

### For each antenna

Install the panel antenna as shown in the illustration.

1. Using the plate, mark the position of desired screw placement.
2. Screw the mounting plate into place with the slide panel protruding towards you.
3. Slide antenna onto mounting plate.

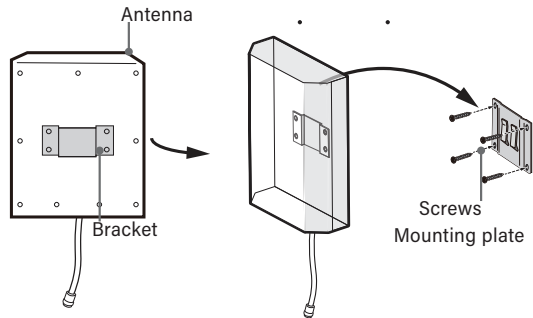

*Panel antenna installation*

## Step 4: Place the inside host unit and connect cables

Place the Inside host unit in your chosen location that is on a flat surface or mounted to a wall. Choose a location that is near a working AC outlet and in an accessible location.

To install the booster to a wall, use the supplied screws or appropriate screws for surface and drill through screw tab holes on unit.



*Inside host unit*



*Connect to ports marked "INSIDE 1" AND "INSIDE 2"*



*Connect to port marked "OUTSIDE"*

Next, connect the outside and inside components by routing the outside cable from the outside amplifier, indoors and connect to the host unit port marked "OUTSIDE".

See page "Routing cable" on page 13 for more information.

### Cable

Connect each antenna to an indoor cable provided with your kit.

Run the cables along route toward the planned location of your inside host unit.

Connect the indoor antennas to the host unit using the provided cables. The cables should connect to the ports on the host unit labeled "INSIDE 1" and "INSIDE 2".

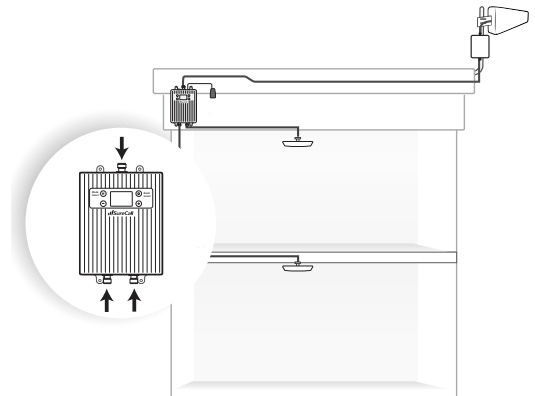

**i** **NOTE:** Do not power on until the system is fully connected.

**i** **NOTE:** This booster should not be used near open fire or flame. Storage and transportation: Store and place in non-extreme room-temperature and dry environment.

## Step 5: Connect to power

Connect the AC power supply to the booster and plug into a 110V AC power outlet. Once the booster has been completely assembled, turn the booster's power switch on.

Note: If the Power LED does not turn ON or the Alert LEDs continue to flash, see the Troubleshooting section.

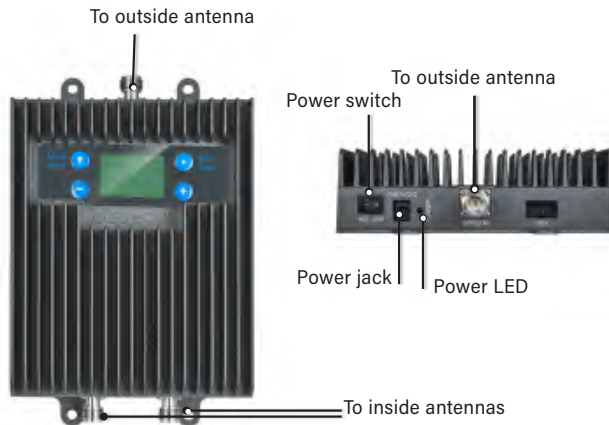

*Host unit diagram*

## BOOSTER TESTING AND OPTIMIZATION

When your system is in place and fully connected, test system performance in locations you have previously experienced poor signal. Verify that you have a reliable connection by taking multiple readings several minutes apart. For instructions on taking measurements with your cell phone, see page 8. Also, verify that you can place and hold a call.

If the signal strength has improved, your booster is working.

Remember that coverage varies based on outdoor signal level, house construction, and antenna placement. Coverage in adjoining rooms will be reduced by walls and building materials.

**The gain settings should always be at maximum level unless otherwise indicated.** They should ONLY be reduced if other recommended actions do not resolve the issue. In any of these cases, the first action should be to increase the antenna isolation between the inside and outside antenna as much as possible.

### Antenna optimization

The 5X Max automatically reduces gain (coverage performance) because of insufficient RF separation between the inside and outside antennas. Consider the options listed in this section to resolve issues with inadequate antenna isolation.

- Verify that a minimum distance of 25 vertical feet has been achieved. 50 ft or more horizontal separation may be needed, however, especially where vertical separation is not possible.
- Check for sources of interference such as cellular modems or hotspots.

- Verify antennas are not placed near a window.
- Ensure that antennas are aimed away from one another.
- Mount the outside antenna at the corner or side of the roof which faces your cell tower.
- Avoid placing / aiming the yagi antenna towards materials (such as windows) where the signal may be reflected towards your home or office.
- Keep in mind, identifying the setup that yields the best possible results for your environment will come from testing -- balancing the elimination of interference and while also receiving the best possible signal.

## Antenna testing

As a final step, identify the precise antenna angle which provides the maximum possible performance. For this step, it's best to have another person inside to report results.

- Rotate the outside antenna around the mast, making angle adjustments in progressively smaller increments until the peak angle is found. Record your results below using one or both methods. After each angle test, power cycle the booster.

There are two methods available to confirm you've achieved the optimum angle for your Yagi antenna:

1. Note the signal reading from the inside antenna's projected coverage area.
2. Make angle adjustments to the Yagi antenna while reading the RSSI number for each band appearing on the LCD screen until the best (or strongest ) value for all bands is found. Record your results below.

Once you've identified the optimum angle, secure the outside antenna in place.

LOCATION	BEFORE Install	Band #	AFTER, Test 1	Band #	Test 2	Band #	Test 3	Band #

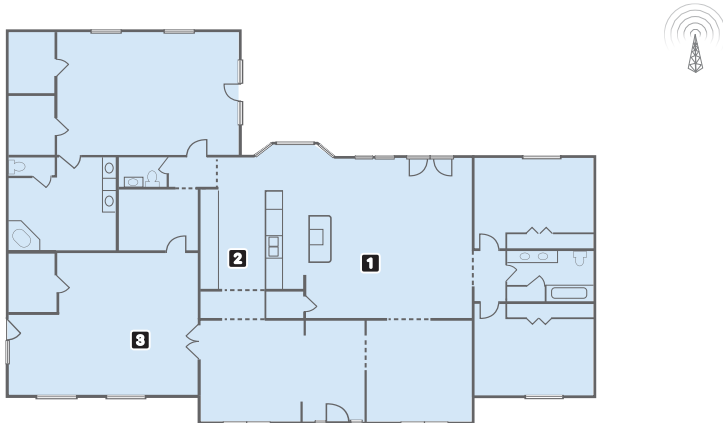

Example testing plan

## LCD INTERFACE

Note the following information:

- Your booster settings should always be at maximum level and only reduced if all other recommended actions have not resolved the issue.
- Most issues can be resolved by addressing antenna separation/isolation. See "Antenna optimization" on page 20 for suggestions regarding antenna isolation.

### LCD display preview and parameters

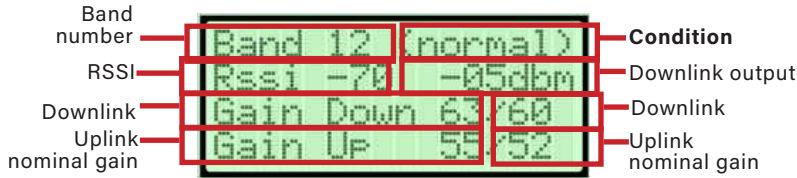

### Conditions defined

Condition	Indication/ Meaning
(Init)	Initializing on power-up
(normal)	Normal operation
(OSC)	Oscillation is detected. Try improving isolation between the outside and inside antenna(s)
(sleep)	After a period of inactivity, a band will enter sleep mode.
(DL-ALC)	Strong input signal is detected and downlink gain has been automatically reduced. Booster performance has not been impacted.
(ComErr)	Communications error between the inside and outside units, usually caused by the cable not being connected or a damaged cable.
(Cable-)	Cable length is too short. It needs to be at least 50 ft. of LMR-400 cable as required by FCC.
(Cable+)	Cable length is too long. It needs to be no more than 150 ft. of LMR-400 cable as required by FCC.

## Parameters of RSSI

### Low band (band12 band13 band5 )

RSSI higher than -81dbm ,display power normal

```
Band 12 (normal)
Rssi -70 -05dbm
Gain Down 63/60
Gain Up 55/52
```

RSSI lower than -81dbm display ---

```
Band 12 (normal)
Rssi --- ---dbm
Gain Down 63/60
Gain Up 55/52
```

### High band (band2 band4)

RSSI higher than -86dbm, display power normal

```
Band 2 (normal)
Rssi -65 -05dbm
Gain Down 63/60
Gain Up 55/52
```

RSSI lower than -86dbm display ---

```
Band 2 (normal)
Rssi --- ---dbm
Gain Down 63/60
Gain Up 55/52
```

## Parameters of uplink gain and downlink gain



### Nominal gain

The rated gain of the device, the current nominal gain of each frequency band of the device is:

	Uplink nominal gain(dB)	Downlink nominal gain(dB)
Band12 (LTE-A)	55	63
Band13 (LTE-V)	55	63
Band5 (CELL)	57	65
Band2 (PCS)	61	70
Band4 (AWS)	61	70

## Real gain

Display the real gain of the device

Manual attenuation, AGC and the adaptation of the device all cause the real gain of the device to change.

Note: When the real gain is OFF, the amplifier is turned off.

For example:

1. Oscillation causes the amplifier to turn off

```
Band 2 ( OSC )
Rssi -65
Gain Down 65/OFF
Gain Up 55/OFF
```

2. Manual attenuation of  $\geq 30$  causes the amplifier to turn off

```
Band 2 (normal)
Rssi -65
Gain Down 63/OFF
Gain Up 55/OFF
```

## MANUAL CONTROLS

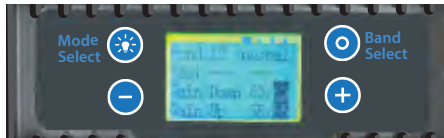

### Band select

Select band using the band switch button to cycle through bands

### Backlight ON/OFF

Pressing the "Mode Select" for one second turns the backlight on or off

### Manual Gain Adjustments

#### Short press

Pressing the [-] or [+] buttons decrease or increases the booster gain

Any adjustment will affect the corresponding uplink or downlink by the same amount

#### Long Press

Pressing the [-] or [+] for more than 5 seconds adjusts the gain by 30 dB

Continuing to press and hold the [-] will turn the amplifier off

## TROUBLESHOOTING

If you have any questions during setup, please contact our US-based support technicians:

Call: 1-888-365-6283 | Email: [support@surecall.com](mailto:support@surecall.com) | Visit: [www.surecall.com/support](http://www.surecall.com/support)

Problem	Resolution
Signal booster has no power	Connect the power supply to an alternate power source. Verify that the power source is not controlled by a switch that has removed power from the outlet. If it remains OFF, contact tech support at: <a href="tel:1-888-365-6283">1-888-365-6283</a> or <a href="mailto:support@surecall.com">support@surecall.com</a>
After completing installation, indoor signal coverage has not improved	Verify that cable connections are tightly fitted to the booster and antennas. Try further separating the booster and antenna. Verify that there is usable signal where the outside antenna is placed. Note: Bars are not always a reliable measure of signal. The best way to confirm signal coverage is the ability to place and hold a call.

## SPECIFICATIONS

Model	5X Max (US and Canada)
Uplink Frequency Range (MHz):	698-716 / 776 – 787 / 824-849 / 1850-1915 / 1710-1755
Downlink Frequency Range (MHz):	728-746 / 746 – 757 / 869-894 / 1930-1995 / 2110-2155
Maximum Gain:	72 dB
Supported Standards:	CDMA, WCDMA, GSM, EDGE, HSPA+, EVDO, LTE and all cellular standards
Input Impedance:	50 $\Omega$
VSWR	$\leq 2.0$
Noise Figure:	<8 dB
AC Input:	Input AC110V, 60 Hz; Output DC 12-15V
Maximum Output Power:	1 Watt EIRP
Downlink Power	+16 dBm
Cable:	SC-400 cable (100 ft)
RF Connectors:	N-Female inside / N-Female outside
Power Consumption:	<25W
<b>5X Max Outside Amp</b>	
Temperature Range:	4° to +158° for optimal performance
Dimensions:	8.63*6.83*2.18 in
Weight:	4.6lb;
Certifications: (Model 5X Max)	FCC ID: RSN-FUSION5XMAX; IC : 7784A-5XMAX
<b>5X Max Inside Host</b>	
Temperature Range:	41 ° to +104° for optimal performance
Dimensions:	9.63*6.50*1.98 in
Weight:	4 lbs
Certifications: (Model 5X MaxS)	FCC ID: RSN-FUSION5XMAX; IC : 7784A-5XMAX

*Note: The term "IC" before the radio certification number only signifies that Industry Canada technical specifications were met.*

## Kitting

Component	Prod No. Description	Gain/Loss					Notes
		LTE-A	LTE-V	800MHz	1900MHz	1700 MHz / 2100 MHz	
Outdoor Antenna*	SC532W	8.5 dBi	8.5 dBi	8.5 dBi	8.5 dBi	8.5 dBi / 8.5 dBi	
Cable between systems*	SC-400-50NN 50 feet	3.01 dB	3.01 dB	3.14 dB	4.31 dB	4.07 dB / 4.56 dB	50 to 150 feet
Indoor Cable*	SC-400-50NN 50 feet	3.01 dB	3.01 dB	3.14 dB	4.31 dB	4.07 dB / 4.56 dB	50 to 150 feet
Indoor Antenna*	SC222W	3 dBi	3 dBi	3 dBi	6 dBi	6 dBi / 6 dBi	
	SC121W	1.2 dBi	1.2 dBi	1.2 dBi	3 dBi	3 dBi / 3 dBi	
	SC302W	2.5 dBi	2.5 dBi	3 dBi	5 dBi	4 dBi / 5 dBi	
	SC323W	2.5 dBi	2.5 dBi	3 dBi	4 dBi	4 dBi / 4 dBi	
	SC528W	3.5 dBi	3.5 dBi	3.5 dBi	7.5 dBi	7.5 dBi / 7.5 dBi	
	SC548W	5 dBi	5 dBi	6 dBi	7 dBi	7 dBi / 7 dBi	
*All equivalent antennas and cables are suitable for use with the Fusion5X Max V1.0							

**FCC 15.105 Statement** This equipment has been tested and found to comply with the limits for a Class B digital device, pursuant to part 15 of the FCC Rules. These limits are designed to provide reasonable protection against harmful interference in a residential installation. This equipment generates, uses and can radiate radio frequency energy and, if not installed and used in accordance with the instructions, may cause harmful interference to radio communications. However, there is no guarantee that interference will not occur in a particular installation. If this equipment does cause harmful interference to radio or television reception, which can be determined by turning the equipment off and on, the user is encouraged to try to correct the interference by one or more of the following measures:

- Reorient or relocate the receiving antenna
- Increase the separation between the equipment and receiver.
- Connect the equipment into an outlet on a circuit different from that to which the receiver is connected
- Consult the dealer or an experienced radio/TV technician for help.

## CONSUMER GUIDELINES

### THIS IS A CONSUMER DEVICE

**BEFORE USE**, you **MUST REGISTER THIS DEVICE** with your wireless provider and have your provider's consent. Most wireless providers consent to the use of signal boosters. Some providers may not consent to the use of this device on their network. If you are unsure, contact your provider.

In Canada, **BEFORE USE** you must meet all requirements set out in ISED [CPC-2-1-05](#)<sup>1</sup>.

You **MUST** operate this device with approved antennas and cables as specified by the manufacturer. Antennas **MUST** be installed at least 20 cm (8 inches) from (i.e., **MUST NOT** be installed within 20 cm of) any person.

You **MUST** cease operating this device immediately if requested by the FCC (or ISED in Canada) or licensed wireless service provider.

**WARNING:** E911 location information may not be provided or may be inaccurate for calls served by using this device.

This device may operate in a fixed location only, for in-building use.

This device complies with Part 15 of the FCC Rules. Operation is subject to the following two conditions: (1) this device may not cause harmful interference, and (2) this device must accept any interference received, including interference that may cause undesired operation.

Register your cellular booster with your wireless carrier at the following urls:

**Verizon:** <http://www.verizonwireless.com/wcms/consumer/register-signal-booster.html>

**AT&T:** <https://securec45.securewebsession.com/attsignalbooster.com/>

**T-Mobile:** <https://support.t-mobile.com/docs/DOC-9827>

**Sprint:** [https://www.sprint.com/legal/fcc\\_boosters.html](https://www.sprint.com/legal/fcc_boosters.html)

**U.S. Cellular:** <http://www.uscellular.com/uscellular/support/fcc-booster-registration.jsp>

### CAN ICES-3 (B)/NMB-3(B) (Canada) :

This Class B digital apparatus meets all requirements of the Canadian Interference Causing Equipment Regulations. Operation is subject to the following two conditions: (1) this device may not cause harmful interference, and (2) this device must accept any interference received, including interference that may cause undesired operation.

The Manufacturer's rated output power of this equipment is for single carrier operation. For situations when multiple carrier signals are present, the rating would have to be reduced by 3.5 dB, especially where the output signal is re-radiated and can cause interference to adjacent band users. This power reduction is to be by means of input power or gain reduction and not by an attenuator at the output of the device.

[1]

For details on the requirements specified in ISED CPC-2-1-05, visit: <http://www.ic.gc.ca/eic/site/smt-gst.nsf/eng/st08942.html>

## WARRANTY

### Three-year product warranty

To activate your three-year manufacturer's warranty, register at [www.SureCall.com/activate](http://www.SureCall.com/activate)

SureCall warrants its products for three years from the date of purchase against defects in workmanship and/or materials. Specifications are subject to change. The three-year warranty only applies to products meeting the latest FCC Certification Guidelines stated on 2/20/2013 and going into effect April 30, 2014. A two-year warranty applies to any products manufactured before May 1, 2014.

Products returned by customers must be in their original, un-modified condition, shipped in the original or protective packaging with proof-of-purchase documentation enclosed, and a Return Merchandise Authorization (RMA) number printed clearly on the outside of the shipping container.

Buyers may obtain an RMA number for warranty returns by calling the SureCall Return Department toll-free at 1-888-365-6283. Any returns received by SureCall without an RMA number clearly printed on the outside of the shipping container will be returned to sender. In order to receive full credit for signal boosters, all accessories originally included in the signal booster box must be returned with the signal booster. (The Buyer does not need to include accessories sold in addition to the signal booster, such as antennas or cables.)

This warranty does not apply to any product determined by SureCall to have been subjected to misuse, abuse, neglect, or mishandling that alters or damages the product's physical or electronic properties.

SureCall warrants to the Buyer that each of its products, when shipped, will be free from defects in material and workmanship, and will perform in full accordance with applicable specifications. The limit of liability under this warranty is, at SureCall's option, to repair or replace any product or part thereof which was purchased up to THREE YEARS after May 1, 2014 or TWO YEARS for products purchased before May 1, 2014, as determined by examination by SureCall, prove defective in material and/or workmanship. Warranty returns must first be authorized in writing by SureCall. Disassembly of any SureCall product by anyone other than an authorized representative of SureCall voids this warranty in its entirety. SureCall reserves the right to make changes in any of its products without incurring any obligation to make the same changes on previously delivered products.

As a condition to the warranties provided for herein, the Buyer will prepay the shipping charges for all products returned to SureCall for repair, and SureCall will pay the return shipping with the exception of products returned from outside the United States, in which case the Buyer will pay the shipping charges.

The Buyer will pay the cost of inspecting and testing any goods returned under the warranty or otherwise, which are found to meet the applicable specifications or which are not defective or not covered by this warranty.

Products sold by SureCall shall not be considered defective or non-conforming to the Buyer's order if they satisfactorily fulfill the performance requirements that were published in the product specification literature, or in accordance with samples provided by SureCall. This warranty shall not apply to any products or parts thereof which have been subject to accident, negligence, alteration, abuse, or misuse. SureCall makes no warranty whatsoever in respect to accessories or parts not supplied by it.

#### Limitations of Warranty, Damages and Liability:

EXCEPT AS EXPRESSLY SET FORTH HEREIN, THERE ARE NO WARRANTIES, CONDITIONS, GUARANTEES, OR REPRESENTATIONS AS TO MERCHANTABILITY, FITNESS FOR A PARTICULAR PURPOSE, OR OTHER WARRANTIES, CONDITIONS, GUARANTEES, OR REPRESENTATIONS, WHETHER EXPRESSED OR IMPLIED, IN LAW OR IN FACT, ORAL OR IN WRITING.

SURECALL AGGREGATE LIABILITY IN DAMAGES OR OTHERWISE SHALL NOT EXCEED THE PAYMENT, IF ANY, RECEIVED BY CELLPHONE-MATE, INC. FOR THE UNIT OF PRODUCT OR SERVICE FURNISHED OR TO BE FURNISHED, AS THE CASE MAY BE, WHICH IS THE SUBJECT OF CLAIM OR DISPUTE. IN NO EVENT SHALL SURECALL BE LIABLE FOR INCIDENTAL, CONSEQUENTIAL, OR SPECIAL DAMAGES, HOWSOEVER CAUSED.

All matters regarding this warranty shall be interpreted in accordance with the laws of the State of California, and any controversy that cannot be settled directly shall be settled by arbitration in California in accordance with the rules then prevailing of the American Arbitration Association, and judgment upon the award rendered may be entered in any court having jurisdiction thereof. If one or more provisions provided herein are held to be invalid or unenforceable under applicable law, then such provision shall be ineffective and excluded to the extent of such invalidity or unenforceability without affecting in any way the remaining provisions hereof.

SureCall has made a good faith effort to ensure the accuracy of the information in this document and disclaims the implied warranties of merchantability and fitness for a particular purpose and makes no express warranties, except as may be stated in its written agreement with and for its customers. SureCall shall not be held liable to anyone for any indirect, special or consequential damages due to omissions or errors. The information and specifications in this document are subject to change without notice.

© 2023. All Rights Reserved. All trademarks and registered trademarks are the property of their respective owners.