



Quick Installation Guide

Fusion2Go® XR Fleet

BEFORE YOU BEGIN

Please note: This product is designed for professional installation as the antenna is mounted through a hole drilled into the vehicle's sheet metal.

A "soft installation" should first be performed by assembling the NMO antenna and routing the cable through an open window. After completing the remaining installation steps and successful operation is verified, proceed with final installation.



Quickly optimize your antenna separation with the 'SureCall' mobile app that is available in the Google Play or Apple's App Store

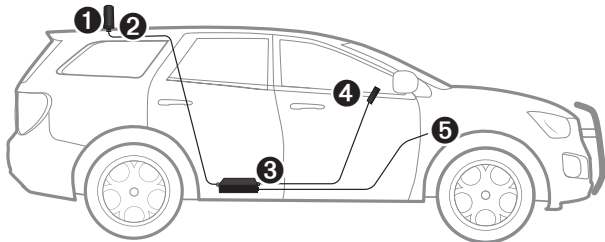

- 1 Outside Antenna
- 2 NMO Mounting Cable
- 3 Booster
- 4 Inside Patch Antenna
- 5 12V Hardwire Power Supply

1. INSTALL OUTSIDE ANTENNA

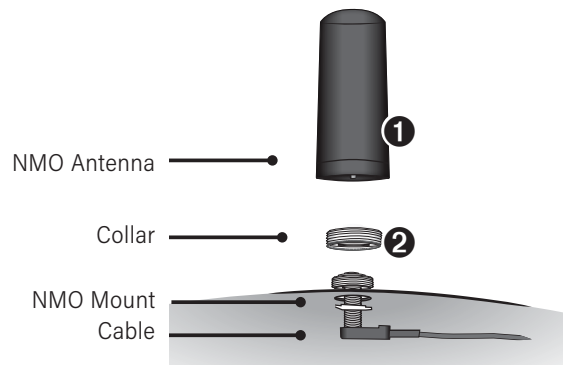

Identify a location on the vehicle's roof that (1) has at least a 12-inch radius clear of obstructions and other radiating elements, such as a radio antenna and (2) at least 6 inches away from any windows.

Using a drill with a 3/8-inch hole saw bit, drill hole in the center of the desired location. Remove the metal collar from the connector and insert the NMO mounting cable through the hole (see above illustration).

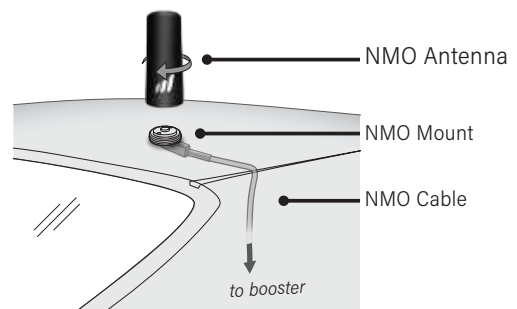

Position threads of the cable mount to extend through the center of drilled hole and above vehicle surface.

Screw the collar to the base mount, ensuring the mount is centered and tighten with a wrench. Next, thoroughly clean the mounting area before screwing the antenna onto the NMO mount. Ensure full contact of the antenna to the vehicle surface.

Note: The outside antenna must not be collocated or operating with any other antenna or booster.

Once the antenna installation is complete, route the NMO Antenna cable from the point of entry to the desired location of the booster. To hide the cable, route behind the headliner cover, interior trim and floor of the vehicle.

Have Questions?

We have answers! Reach out to our US-based support team:

- Call: 1-888-365-6283
- Email: support@surecall.com
- Visit: www.surecall.com

Industry-Best Three-Year Warranty

Thank you for your SureCall purchase. Please take the time to register your new product at www.surecall.com/activate

SureCall warrants its products for three years from the date of purchase against defects in workmanship and/or materials.

Products returned by customers must be in their original, un-modified condition, shipped at the customer's expense in the original or protective packaging with proof-of-purchase documentation enclosed and a Return Merchandise Authorization (RMA) number printed clearly on the outside of the shipping container. RMA numbers are obtained by contacting Customer Support.

This warranty does not apply to any product determined by SureCall to have been subjected to misuse, abuse, neglect, or mishandling that alters or damages the product's physical or electronic properties.

For complete warranty text, including limitations and liability, see the Fusion2Go XR Fleet full user manual, available online.

2. INSTALL INSIDE ANTENNA

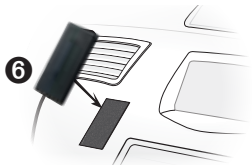

Identify a location for the inside antenna on or near your front dashboard that is: (1) Within 2-3 feet of typical cell phone location, (2) At least 8 inches (20cm) from cellular devices and (3) At least 4 inches (10cm) from metal.

To achieve adequate antenna isolation, it may be necessary to lower the placement of your inside antenna. The SureCall app can help you to determine optimal placement.

Peel Velcro backing and apply to a clean dry surface in your chosen location.

3. PLACE BOOSTER AND CABLES

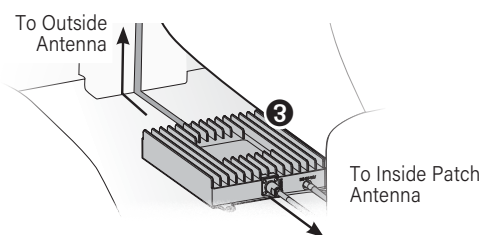

Select a well-ventilated location for the booster that is away from excessive heat, direct sunlight, and moisture. Beneath a seat or within the front console is suggested.

Connect the cable from the outside antenna to the connection marked OUTSIDE and connect the cable from inside patch antenna to the connection marked INSIDE. Hand tighten the connections and secure any loose cable.

4. CONNECT TO POWER

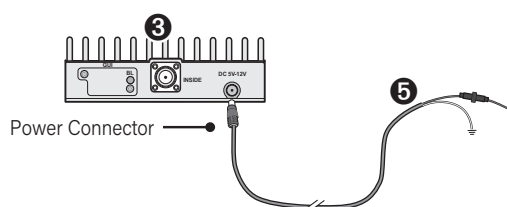

Before and while wiring the power supply, disconnect vehicle battery. Hardwire installation requirements vary by vehicle. The following is only a general guide. Check with your manufacturer's vehicle for specific electrical placement or requirements.

Locate a +12V accessory ("ACC") wire that will switch on and off with the ignition. Connect to the power source and ground.

Once connections are complete, verify operation by connecting the DC power cord connector to the signal booster. The Power LED on the signal booster will illuminate to indicate it is receiving power and is ready for use. Permanently secure power cable.

Note: This booster is also compatible with an AC power adapter, SureCall part # SC-AC-5.9V2.8A-B.

Verify Your System is Working

Place a call in a location where you previously experienced poor cell service and confirm that your phone is receiving boosted signal. To improve performance, antenna adjustments may be needed. Review the following potential causes:

(1) Verify the two antennas have sufficient separation/isolation from the other and (2) at least 12 inches from other radiating elements.

Note: Bars are not always a reliable measure of signal. The best way to confirm signal coverage is the ability to place and hold a call.

'POWER' LED

During initialization, the LED will briefly flash YELLOW/RED. This is part of normal operation.

LED State	Status	Indication
Solid GREEN	Normal	Normal
Solid RED	Alert - Oscillation detected	Indicates that oscillation has caused the booster to shut off. Antenna repositioning is needed. Verify that there is sufficient separation between the outside and inside antennas, as well as any potentially interfering objects or antennas.

Troubleshooting

Problem: Signal booster has no power

Connect the power supply to an alternate power source. Verify that the power source is not controlled by a switch that has removed power from the outlet.

If the POWER LED on the signal booster remains OFF, contact tech support at: 1-888-365-6283 or support@surecall.com

Problem: Following installation, signal coverage has not improved

(1) Verify that all cable connections are tightly fitted. (2) Try further separating the antennas. (3) Verify that there is usable signal where the outside antenna is placed.

Specifications

Uplink Frequency (MHz):	698-716 / 776-787 / 824-849 / 1850-1915 / 1710-1755
Downlink Frequency (MHz):	728-746 / 746-757 / 869-894 / 1930-1995 / 2110-2155
Supported Standards:	5G, 4G, LTE cellular standards
Cellular Bands	12 / 17 / 13 / 5 / 2 / 25 / 4
Maximum Gain:	50 dB
Input Impedance:	50 Ω
Gain Adjustment:	20 dB (Automatic)
Max Uplink Power:	29.0 dBm
VWSR:	≤ 2.0
Noise Figure	≤ 6 dB
Max Output Power:	1 Watt EIRP
Exterior Cable:	LMR 200 / 15 ft
Interior Cable	302 series / 10 ft
RF Connectors:	FME Male (both ends)
DC Power:	6-15V
Power Consumption:	≤ 12W
Operation Temp:	-4° to +158° F
Certification:	FCC ID: RSN-FUSION2GO5G Contains FCC ID: XPYNINAB1

This is a CONSUMER device

BEFORE USE, you **MUST REGISTER THIS DEVICE** with your wireless provider and have your provider's consent. Most wireless providers consent to the use of signal boosters. Some providers may not consent to the use of this device on their network. If you are unsure, contact your provider.

You **MUST** operate this device with approved antennas and cables as specified by the manufacturer. Antennas **MUST** be installed at least 20 cm (8 Inches) from any person. You **MUST** cease operating this device immediately if requested by the FCC or a licensed wireless service provider.

WARNING: E911 location information may not be provided or may be inaccurate for calls served by using this device.

Operation is subject to the following two conditions: (1) this device may not cause harmful interference, and (2) this device must accept any interference received, including interference that may cause undesired operation.

The outside antenna must not be collocated or operating with any other antenna or booster.