

# Fusion5S<sup>TM</sup> 2.0

*All-Carrier Five-Band Signal Boosters for Large Home /Small Office*

User Guide



## INTRODUCTION

Thank you for purchasing SureCall's Fusion5s 2.0 cellular signal booster kit. Fusion5s 2.0 was specifically designed to eliminate frustrations over dropped calls, limited range and slow data rates by amplifying incoming and outgoing cellular signals in homes up to 10,000 square feet.

The Fusion5s provides enhanced cellular signals for multi-carrier voice and data reception.

If you have any questions while assembling this kit please contact tech support at

**Call:** 1-888-365-6283

**Email:** [support@surecall.com](mailto:support@surecall.com)

Or, **visit:** [www.surecall.com/support](http://www.surecall.com/support)



Watch installation, optimization and troubleshooting techniques in our SureCall University YouTube channel



@SureCall



Stay up to date with all things SureCall

## HOW IT WORKS

SureCall's Fusion5s 2.0 is a high-quality bidirectional signal booster that enhances cellular signals to areas that are prone to weak cellular coverage.

Fusion5s 2.0 works with two types of antennas: An inside antenna that communicates with your cell phone and an outside antenna that communicates with the cell tower.

1. One outside antenna is used to collect signal from the cell tower.
2. The antenna then sends the signal to the booster through coax cable.
3. The booster amplifies the cell signal and rebroadcasts the signal indoors via the inside antenna or antennas to all mobile devices within range.
4. The system also works in reverse amplifying outgoing signal back to the tower.

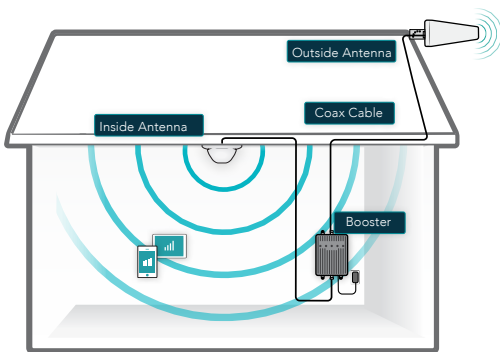

**TABLE OF CONTENTS**

INTRODUCTION .....2

HOW IT WORKS.....3

PACKAGE CONTENTS .....5

BEFORE INSTALLATION .....7

    Installation Overview.....7

INSTALLATION .....8

    Step 1. Find the area with the Strongest Signal .....8

    Step 2. Install the Outdoor Antenna.....9

        Option A: Outdoor Omni Antenna.....9

        Option B: Outdoor Yagi Antenna .....11

    Step 3. Install Indoor Antenna(s) .....12

        Option A: Indoor Dome Antenna(s) .....13

        Option B: Panel Antenna .....13

    Step 4. Install the Signal Booster.....14

        Booster Hardware.....14

LED INDICATORS .....15

    LED Information.....15

TROUBLESHOOTING .....15

    If you Want to Improve Coverage .....16

SPECIFICATIONS .....16

    Kitting Information .....17

CONSUMER GUIDELINES.....18

WARRANTY.....19

    Three-Year Product Warranty .....19

## PACKAGE CONTENTS

1. Unpack all package contents. For missing or damaged items, contact your reseller.
2. Turn over the signal booster and record the model and serial number for reference:

Serial #: \_\_\_\_\_

Purchase Date: \_\_\_\_\_

3. Keep the carton and packing material to store the product in case you need to return it.

Standard Fusion5s 2.0 signal booster packages include the following items:

- SureCall Fusion5s 2.0 booster and power supply
- One outside antenna (Omni or Yagi)
- One outside cable (75 ft)
- One or two inside antennas (depending on your kit; Omni dome or panel)
- Inside cable (30 ft.; one cable per inside antenna)
- plus 1 cable splitter (for multi-antenna kits)

### Booster



Fusion5s 2.0

### Outside Antenna (options)



Omni



Yagi

### Outside Cable



75 ft cable—SC-400

### Inside Antenna (options)



Dome(s)



Panel(s)

### Inside Cable



30 ft cable—SC-400







Splitter (for multiple antenna kits)

## TABLE OF CONTENTS

Note: Fusion5s 2.0 is available in six kits

Model number	Model name	Outside Antenna Type	Outside Cable Length	Inside Antenna		Inside Cable	
				(Qty)	Type	(Qty)	Length Splitter & cable
SC-PolysH/O-72-OD-Kit	Fusion5s 2.0 Omni/Dome	Omni	75 ft	(1)	Dome	(1)	30 ft -
SC-PolysH/O-72-OP-KIT	Fusion5s 2.0 Omni/Panel	Omni	75 ft	(1)	Panel	(1)	30 ft -
SC-PolysH/O-72-YD-KIT	Fusion5s 2.0 Yagi/Dome	Yagi	75 ft	(1)	Dome	(1)	30 ft -
SC-PolysH/O-72-YP-KIT	Fusion5s 2.0 Yagi/Panel	Yagi	75 ft	(1)	Panel	(1)	30 ft -
SC-PolysH/O-72-YD2-Kit	Fusion5s 2.0 Yagi/2-Dome	Yagi	75 ft	(2)	Dome	(2)	30 ft 1
SC-PolysH/O-72-YP2-Kit	Fusion5s 2.0 Yagi/2-Panel	Yagi	75 ft	(2)	Panel	(2)	30 ft 1

Fusion 5s 2.0 kits use the following antenna options based on environmental and coverage requirements..

	Antenna Type	Model No.	Usage Coverage
<b>Outside Antenna Options</b>			
	Outdoor omnidirectional antenna 2-3 dBi / 3-4 dBi	SC-288W	Omni antennas are the ideal solution for sending/receiving signal from all directions.
	Outdoor directional Yagi antenna 8 dBi	SC-230W	The Yagi antenna is a higher gain solution ideal for low signal locations where the antenna can be aimed to your closest tower.
<b>Inside Antenna Options</b>			
	Indoor omnidirectional dome antenna 2 dBi / 5 dBi	SC-222W	The dome antenna, generally ceiling-mounted, is omnidirectional, sending/receiving signal in all directions indoors.
	Indoor directional panel antenna 7 dBi / 10 dBi	SC-248W	The panel antenna, generally wall-mounted, provide directional indoor coverage. H. beamwidth: 120°; V beamwidth: 100°

**Warning:** Unauthorized antennas, cables, and/or coupling devices are prohibited by FCC rules. Please contact the FCC for details: 1-888-CALL-FCC. Changes or modifications not expressly approved by SureCall could void the user's authority to operate the equipment.

## BEFORE INSTALLATION

- Prior to securing the location of any booster parts, a “soft install” is recommended as adjustments may be needed to optimize performance.
- Make sure you have sufficient separation between outdoor antenna and indoor antennas. At least 50 ft. is recommended for best performance.
- Ensure sufficient cable length between the outside antenna location and booster location. The length of the provided cable is 75 ft.
- For kits that use directional antennas (outside or inside), the directional antenna(s) should be oriented in a way that do not “face” the other antenna (see “Antenna Aiming” Diagram).

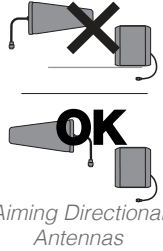

### Installation Overview

- Step 1. Find the outside area that has the strongest signal.
  - Step 2. Install the outdoor antenna in the area identified in step 1.
  - Step 3. Install the indoor antenna(s) where signal is needed.
  - Step 4. Place the booster in appropriate location and route cables from outdoor and indoor antennas to the booster.
  - Step 5. Connect cables to the booster and finally, the booster to an AC power source.
- Check System and optimize Installation, if needed

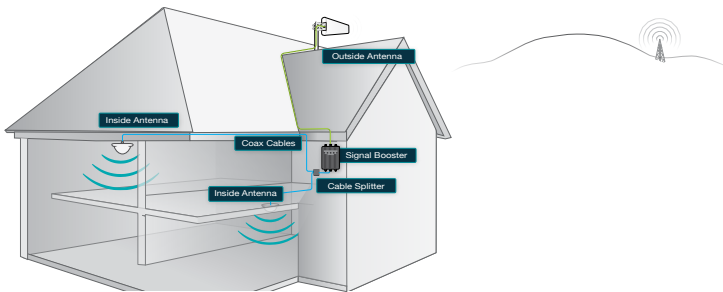

Antenna Separation

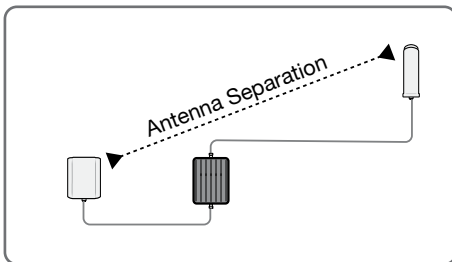

#### Outdoor/ Indoor Antenna Separation

A minimum of 50 ft. of separation between the outdoor antenna and indoor antennas is recommended for best performance.

Reducing antenna separation will reduce the coverage provided by the booster and generally, additional separation will provide better performance.

## INSTALLATION

### Step 1. Find the area with the Strongest Signal

Using your phone, identify the outside location with the strongest signal for placement of your outside antenna. Generally, this is found above the roofline on the side facing your nearest cell tower and as high as possible – where the antenna can 'see' your cell tower. To find the location of your carrier's closest cell tower, go to [www.antennasearch.com](http://www.antennasearch.com).

The coverage area that the booster provides is directly related to the strength of incoming signal received by the outdoor antenna. Mounting the outside antenna where the signal is the strongest will provide the best results. **Please note**, if signal is extremely weak where the outside antenna is installed, indoor coverage will be limited.

Note that Bars are not always a reliable measure of signal. The best way to confirm signal coverage is the ability to place and hold a call.

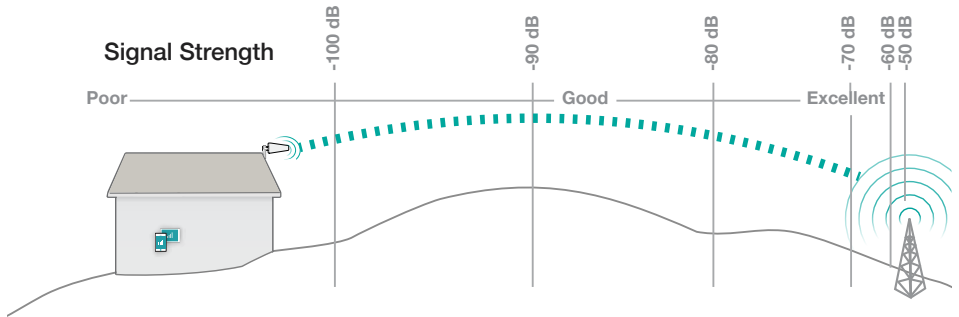

## Step 2. Install the Outdoor Antenna

After identifying the area of strongest signal, choose the surface where you will mount your outside antenna.

The location should allow for sufficient separation between the outside antenna and inside antennas. The minimum separating distance recommended for this booster is 50 Ft. Vertical separation is preferred as it is more effective than horizontal separation. See “Antenna Separation” on page 7.

The location should allow for sufficient separation between the outside antenna and inside antenna. Vertical separation is preferred as it is more effective than horizontal separation.

The minimum separating distance recommended is 50 feet; however, increased separation, especially where vertical separation cannot be achieved.

**IMPORTANT:** Do not collocate antennas or operate the outdoor antenna with any other antenna or signal booster.

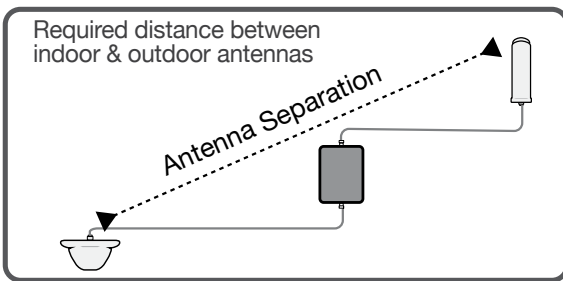

### Outdoor/ Indoor Antenna Separation

A minimum of 50 ft. of separation between the outdoor antenna and indoor antennas is recommended for best performance.

Reducing antenna separation will reduce the coverage provided by the booster and generally, additional separation will provide better performance.



Option A:  
Omni Antenna



Option B:  
Yagi Antenna

### Option A: Outdoor Omni Antenna

The omni antenna is omni-directional, which receives and sends signals in a 360° radius. The provided hardware allow for either a surface mount or pole-mount.

For best performance, be sure to place the outdoor antenna at least 50 feet from the indoor antennas. Place the antenna as high as possible. Make sure that the mounting area has at least a 36-inch radius clear of obstructions and other radiating elements. The antenna should be mounted in an upright position. See illustration.

# INSTALLATION

To mount antenna to a vertical surface:

1. Using vertical plate of L-bracket, mark position of desired placement.
2. Place vertical L-bracket into desired location and tap the screws, head first, along with sleeve, into stucco 1/2 to 5/8 inches deep into place. (Note: Alternate screws may be required for different surfaces such as wood or concrete.)
3. In this order, place washer, lock washer and nut on each screw and tighten until secure. When tightening screw, sleeve will expand to secure plate.
4. Use provided screws to secure antenna base onto horizontal plate.
5. Connect antenna to cable connector for the outdoor cable provided with your kit and run along route to planned location of your booster.

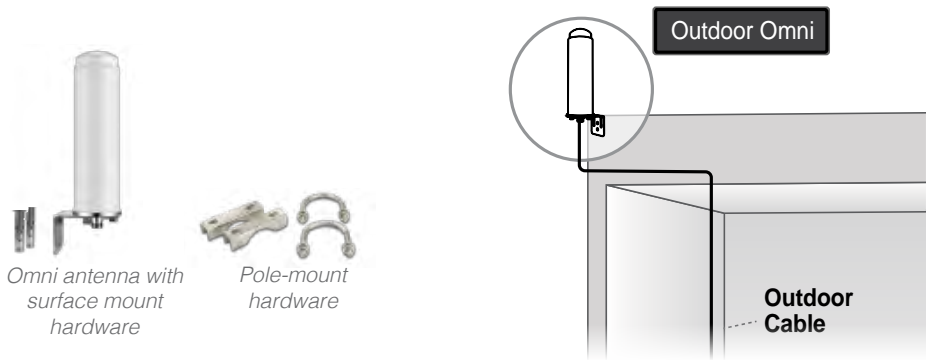

## Surface Mount

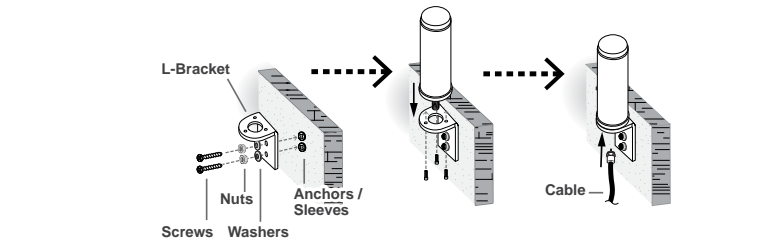

## Pole Mount

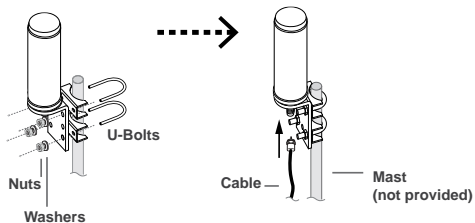

## Option B: Outdoor Yagi Antenna

Before installing a Yagi directional antenna, note that the antenna should be mounted on a pole or pipe (not provided), at the highest possible location above the roofline where the antenna can “see” your cell tower.

The antenna is mounted horizontally and aimed in the direction of your nearest cell tower. The location of your carrier’s closest cell tower may be identified using [www.antennasearch.com](http://www.antennasearch.com).

Once you have identified your install location, ensure that the mounting area has at least a 3-ft radius clear of obstructions and other radiating elements

As shown, assemble the u-bolt, bracket, nuts and washers onto a pole or pipe as shown in the illustration. Keep the connections loose enough to allow the antenna to rotate until the optimum direction is found.

Once the outside antenna is secured to a pipe or pole, Connect antenna to cable connector for the outdoor cable provided with your kit and run along route to planned location of your booster.

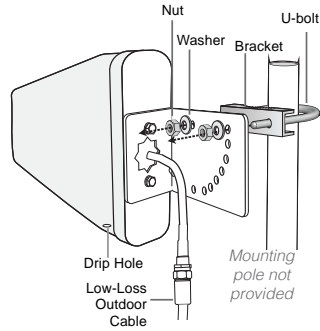

*Ensure that the mounting area has at least a 3-ft radius clear of obstructions and other radiating elements and orient the antenna with the drip hole at the bottom.*

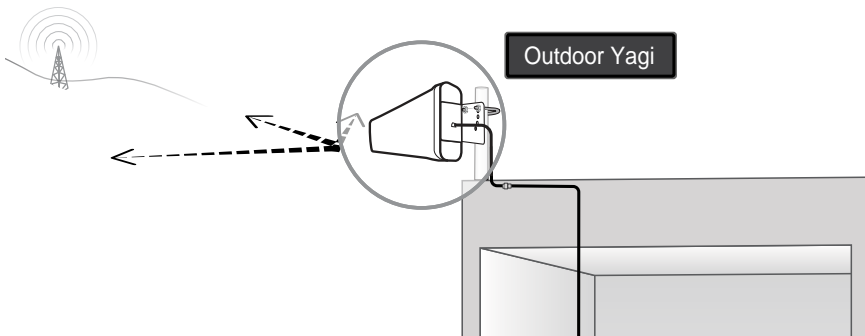

### Step 3. Install Indoor Antenna(s)

Indoor antennas may be either omni-directional ceiling mount or directional panel antennas. One indoor cable is provided per antenna. For kits with multiple antennas, a cable splitter and joining cable is also supplied.

It is highly recommended that you complete test the placement of your system before a securing the permanent installation for each part.

- For indoor dome antennas, mount on a ceiling in a central location where signal is needed.
- For indoor panel antennas, mount on a wall that faces in the direction signal is needed.



*Option A:  
Omni Antenna*



*Option B:  
Directional Antenna*



Splitter (for multiple antenna kits)

The antenna location should allow for sufficient separation between the outside antenna and inside antenna. Vertical separation is preferred as it is more effective than horizontal separation.

The minimum separating distance recommended is 50 vertical feet; however, increased separation, may be needed, especially where vertical separation cannot be achieved.

Range provided by an antenna is dependent on the following factors:

1. Signal level received by the outdoor antenna
2. Physical obstructions between the antenna and mobile devices
3. Isolation / separation between the outdoor and indoor antennas

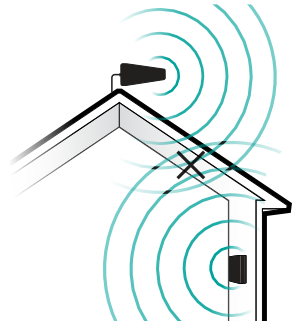

*Antenna aiming and Isolation  
A significant factor in determining  
booster coverage performance*

## Option A: Indoor Dome Antenna(s)

The SC-222W wideband antenna is an omni-directional interior antenna that sends and returns signals from all sides.

1. Drill a 20 mm diameter hole in the ceiling. The ceiling thickness should not exceed 20 mm.
2. Unscrew fixing nut from antenna. Place antenna cable through ceiling hole.
3. Screw the fixing nut back onto the antenna and cable on the crawl-space side of the ceiling and tighten fixing nut to secure antenna.
4. Once secure, connect one end of the indoor cable to the antenna connector and route cable toward the planned location of your booster.
5. For kits with multiple antennas route both cable lengths toward the booster, allowing the cables to meet at the provided splitter. ports and route the splitter cable to the planned location of the booster.

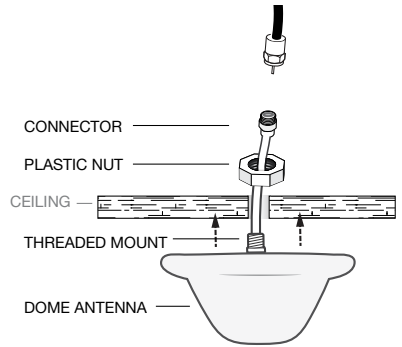

## Option B: Panel Antenna

SureCall's Inside panel antennas are directional with a 120° reach. They should be mounted facing the area signal is needed and away from the outdoor antenna (See "Antenna aiming and Isolation" on page 12).

Choose a vertical surface that is the approximate height of normal cell phone use. The antenna may be concealed behind a wall provided there are no materials that could obstruct signals.

Besides the antenna itself, parts include mounting equipment for a flat horizontal surface.

1. Using plate, mark position of desired screw placement.
2. Screw mounting plate into place with the slide panel protruding towards you.
3. Slide antenna securely onto mounting plate.
4. Following antenna placement, connect antenna to one end of cable for the indoor antenna cable and route toward the planned location of your booster.
5. For kits with multiple antennas route both cable lengths toward the booster, allowing the cables to meet at the provided splitter. ports and route the splitter cable to the planned location of the booster.

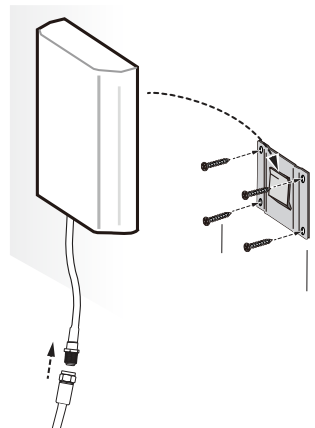

Storage and transportation: Store and place in non-extreme room temperature and dry environment only. This antenna should not be used near open flames.

## Step 4. Install the Signal Booster

1. Select a location close to a working AC outlet. Do not expose the signal booster to excessive heat, direct sunlight, moisture, and airtight enclosures. If you'd like to mount the booster to a wall, mark location of screw tabs on the wall in the desired location.
2. Use supplied or appropriate screws for surface of mounting location and drill through screw tab holes on booster.
3. Connect the outside antenna cable to the signal booster connector marked OUTSIDE and tighten the connection.
4. Connect the inside antenna cable to the signal booster connector marked INSIDE and tighten the connection.
5. Connect the AC power cord to the signal booster.
6. Connect the plug on the other end of the 110V AC power outlet.
7. Turn the booster's power switch on.

*Note: This booster is rated for 5-20V input voltage. DO NOT use the booster with a higher voltage power supply. This can damage the booster, cause personal injury and void your warranty.*

*Note: Power LED does not turn ON or the Alert LEDs continue to flash, see PAGE 15.*

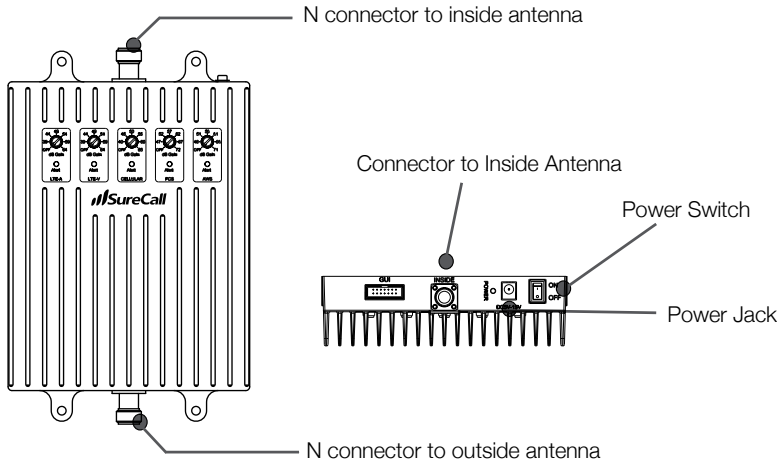

## Booster Hardware

The following image shows the key hardware components on the cellular booster. Refer to this image as you install your Fusion5s 2.0 kit components.

## LED INDICATORS

Please note the following information:

- Only the presence of red or RED-yellow LEDs indicate the presence of an unresolved issue.
- Your booster switches should always be at maximum level unless the control light for a specific frequency band is flashing red or red-yellow. In either case, only reduce gain if other recommended actions do not resolve the issue.

### LED Information

Color	LED	Resolution
Green	Solid	Indicates that the frequency band is in use. <b>This is part of normal operation.</b>
Green	Flashing	Indicates that the booster is functioning properly by using Automatic Gain Control (AGC) technology to stabilize the signal entering your booster from the outside antenna. <b>This is part of normal operation.</b>
Yellow / Red	Alternately Flashing	Indicates that the booster is receiving too much signal which could cause the affected band to automatically turn off. When this happens: <ul style="list-style-type: none"> <li>• For kits using an OMNI outside antenna, relocate the outside antenna to a location where the signal is weaker.</li> <li>• For kits using a YAGI outside antenna, turn the antenna in short increments away from the signal source.</li> <li>• Add an inline attenuator to the cable coming into the outside port of the booster.</li> <li>• Though not desirable as amplification will not be optimum, lower the dB gain setting in small increments until the light turns green.</li> </ul>
Red	Flashing	The frequency band is off due to overpower. This can happen when the gain has been turned too low. To resolve, see the above suggestions.

## TROUBLESHOOTING

Problem	Resolution
Signal booster has no power	Verify that the booster switch is turned on. Be sure the power source is not controlled by a switch that can remove power from the outlet by connecting to an alternate power source. If the POWER LED on the signal booster remains OFF, contact tech support at: 1-888-365-6283 or support@surecall.com
After installing your booster system, coverage has not improved.	Verify that cable connections are tightly fitted to the booster and antennas. Check the installation of your outdoor antenna. Ensure that the mounting area is clear of obstructions and other radiating elements. For kits that use a directional Yagi antenna, verify that the antenna is properly aimed in the direction of your carrier's closest cell tower. Check the outdoor signal strength at the site the outdoor antenna. If signal level is low, your resulting coverage will be limited. Remember that Bars are not always a reliable measure of signal. The best way to confirm signal coverage is the ability to place and hold a call.

## If you Want to Improve Coverage

1. Find a location that receives a stronger signal and relocate the outside antenna to that location.
2. Increase the distance between the outside and inside antennas.
3. Be sure your signal booster's dB gain is turned up to maximum gain on each dial.

Remember, Bars are not always a reliable measure of signal. The best way to confirm signal coverage is the ability to place and hold a call.

## SPECIFICATIONS

Uplink Frequency Range (MHz):	698–716 / 776–787 / 824–849 / 1850–1915 / 1710–1755
Downlink Frequency Range (MHz):	728–746 / 746–757 / 869–894 / 1930–1995 / 2110–2155
Input / Output Impedance:	50 Ω
Maximum Gain:	72 dB
Noise Figure:	8 dB
VWSR:	≤2.0
Supported Standards:	CDMA, WCDMA, GSM, EDGE, HSPA+, EVDO, LTE and all cellular standards
AC Input:	Input AC 110 V, 60 Hz / Output DC 12 V
Maximum Output Power:	1 Watt EIRP
Max Downlink:	+13 dB
Cable:	SC-400
RF Connectors:	N Female (both ends)
Power Consumption:	<25 W
Operation Temperature:	-4° F to +158° F
Dimensions:	9.6 x 6.46 x 2 inches
Weight:	4.6 lbs
FCC ID	RSNFUSION5S-X20

*Warning: Any product modifications that use unauthorized antennas, cables, and/or coupling devices are prohibited by the FCC. Contact FCC for details: 1-888-CALL-FCC. Changes or modifications not expressly approved by SureCall could void the user's authority to operate the equipment.*

**15.105** This equipment has been tested and found to comply with the limits for a Class B digital device, pursuant to Part 15 of the FCC Rules. These limits are designed to provide reasonable protection against harmful interference in a residential installation. This equipment generates, uses and can radiate radio frequency energy and, if not installed and used in accordance with the instructions, may cause harmful interference to radio communications. However, there is no guarantee that interference will not occur in a particular installation. If this equipment does cause harmful interference to radio or television reception, which can be determined by turning the equipment off and on, the user is encouraged to try to correct the interference by one or more of the following measures:

- Reorient or relocate the receiving antenna.
- Increase the separation between the equipment and receiver.
- Connect the equipment into an outlet on a circuit different from that to which the receiver is connected.
- Consult the dealer or an experienced radio/TV technician for help.

## Kitting Information

Component	Prod No. Description	Gain/Loss				
		LTE-A	LTE-V	800MHz	1900 MHz	1700 MHz/2100 MHz
Outdoor Antenna*	SC-288W	3 dBi	3 dBi	3 dBi	4 dBi	4 dBi / 4 dBi
	SC-230W	10 dBi	10 dBi	10 dBi	10 dBi	10 dBi / 10 dBi
Outdoor Cable*	SC-400-75NN, 75-ft	4.22 dB	4.22 dB	4.41 dB	6.17 dB	5.8 dB/6.54 dB
	SC-240-40-FN, 40-ft	3.52 dB	3.52 dB	3.98 dB	6.52 dB	6.12 dB /6.92 dB
Indoor Cable*	SC2-40-20FN, 20-ft	2.06 dB	2.06 dB	2.29 dB	3.56 dB	3.36 dB /3.76 dB
	SC4-00-20NN, 20-ft	1.57 dB	1.57 dB	1.62 dB	2.09 dB	1.99 dB / 2.18 dB
	SC-400-30NN, 30-ft	2.05 dB	2.05 dB	2.12 dB	2.83 dB	2.68 dB / 2.98 dB
	SC-400-50NN,50-ft	3.01 dB	3.01 dB	3.14 dB	4.31 dB	4.07 dB / 4.56 dB
	SC-400-75NN, 75-ft	4.22 dB	4.22 dB	4.41 dB	6.17 dB	5.8 dB / 6.54 dB
Indoor Antenna*	SC-222W	3 dBi	3 dBi	3 dBi	6 dBi	6 dBi/6 dBi
	SC-228W	3.5 dBi	3.5 dBi	3.5 dBi	7.5 dBi	7.5 dBi/7.5 dBi
	SC-248W	7 dBi	7 dBi	7 dBi	10 dBi	10 dBi / 10 dBi
4-way Splitter	SC-WS-4	-6.5 dB	-6.5 dB	-6.5 dB	-6.5 dB	-6.5 dB
2-way Splitter	SC-WS-2	-3.5 dB	-3.5 dB	-3.5 dB	-3.5 dB	-3.5 dB

\* All equivalent antennas and cables are suitable for use with the Fusion5s V2.0 booster.

Component	Prod NO,	Maximum Gain	Minimum Gain
Outdoor Antenna	SC-288W	4 dBi	3 dBi
	SC-230W	10 dBi	10 dBi
Indoor Antenna	SC-222W	6 dBi	3 dBi
	SC-228W	7.5 dBi	3.5 dBi
	SC-248W	10 dBi	7 dBi

### Note1: One Indoor Antenna Kit

Component	Prod NO, Description	Quantity	Notes
Outdoor Antenna	SC-230W, Yagi	1 pc	
Outdoor Cable	SC-240-40FN, 40-ft	1 pc	40 Feet or longer
Indoor Cable	SC-400-75NN 75-ft	1 pc	75 Feet or longer
Indoor Antenna	SC-222W, dome	1 pc	SC-222W or other antenna with gain lower than SC-222W

\* All equivalent antennas and cables are suitable for use with the Fusion5s V2.0 booster.

### Note2: Two Indoor Antenna Kit

Component	Prod NO. Description	Quantity	Notes
Outdoor Antenna	SC-230W, Yagi	1 pc	
Outdoor Cable	SC-240-40FN, 40-ft	1 pc	40 Feet or longer
Indoor Cable	SC-400-20NN, 20-ft	1 pc	20 Feet or longer
Splitter	SC-WS-2	1 pc	
Cable After Splitting	SC-400-50NN, 50-ft	2 pcs	50 Feet or longer
Indoor Antenna	SC-248W, Panel	2 pcs	SC-248W or other antenna with gain lower than SC-248W

\* All equivalent antennas and cables are suitable for use with the Fusion5s V2.0 booster.

## CONSUMER GUIDELINES

### This is a CONSUMER device

BEFORE USE, you MUST REGISTER THIS DEVICE with your wireless provider and have your provider's consent. Most wireless providers consent to the use of signal boosters. Some providers may not consent to the use of this device on their network. If you are unsure, contact your provider.

In Canada, BEFORE USE you must meet all requirements set out in ISED [CPC-2-1-05](#)<sup>1</sup>

You MUST operate this device with approved antennas and cables as specified by the manufacturer. Antennas MUST be installed at least 20 cm (8 inches) from (i.e. MUST NOT be installed within 20 cm of) any person.

You MUST cease operation of this device immediately if requested by the FCC (or ISED in Canada) or a licensed wireless service provider.

**WARNING:** E911 location information may not be provided or may be inaccurate for calls served by using this device.

This device may operate in a fixed location only, for in-building use.

### Ce produit est un appareil de CONSOMMATION

AVANT DE L'UTILISER, vous DEVEZ ENREGISTRER CE DISPOSITIF auprès de votre fournisseur de services cellulaires et obtenir son consentement. La plupart des fournisseurs de services cellulaires autorisent l'utilisation d'amplificateurs de signal. Il se peut que certains fournisseurs n'autorisent pas l'utilisation de ce dispositif sur leur réseau. Si vous n'êtes pas sûr, contactez-le.

Au Canada, AVANT DE L'UTILISER vous devez répondre à toutes les exigences ISED [CPC-2-1-05](#)<sup>2</sup>

Vous DEVEZ utiliser ce dispositif avec les antennes et les câbles autorisés, tel que le spécifie le fabricant. Les antennes DOIVENT être installées à au moins 20 cm (8 po) (NE DOIVENT PAS être installées à moins de 20 cm) de toute personne avoisinante.

Vous DEVEZ arrêter cet appareil immédiatement à la demande de la FCC (ISED au Canada) ou de tout fournisseur de services cellulaires autorisé.

**AVERTISSEMENT:** Il se peut que les informations relatives à la localisation E911 ne soient pas disponibles ou soient inexactes pour les appels qui utilisent cet appareil.

Cet appareil peut fonctionner seulement à un emplacement fixe à l'intérieur d'un bâtiment;

Register your cellular booster with your wireless carrier at the following urls:

**Verizon:** <http://www.verizonwireless.com/wcms/consumer/register-signal-booster.html>

**AT&T:** <https://securec45.securewebsession.com/attsignalbooster.com/>

**T-Mobile:** <https://support.t-mobile.com/docs/DOC-9827>

**Sprint:** [https://www.sprint.com/legal/fcc\\_boosters.html](https://www.sprint.com/legal/fcc_boosters.html)

**U.S. Cellular:** <http://www.uscellular.com/uscellular/support/fcc-booster-registration.jsp>

This device complies with Part 15 of FCC Rules. Operation is subject to the following two conditions: (1) this device may not cause harmful interference, and (2) this device must accept any interference received, including interference that may cause undesired operation.

**WARRANTY****Three-Year Product Warranty****To activate your three-year manufacturer's warranty, register at [www.SureCall.com/activate](http://www.SureCall.com/activate)**

SureCall warrants its products for three years from the date of purchase against defects in workmanship and/or materials. Specifications are subject to change. The three-year warranty only applies to products meeting the latest FCC Certification Guidelines stated on 2/20/2013 and going into effect April 30, 2014. A two-year warranty applies to any products manufactured before May 1, 2014.

Products returned by customers must be in their original, un-modified condition, shipped in the original or protective packaging with proof-of-purchase documentation enclosed, and a Return Merchandise Authorization (RMA) number printed clearly on the outside of the shipping container.

Buyers may obtain an RMA number for warranty returns by calling the SureCall Return Department toll-free at 1-888-365-6283. Any returns received by SureCall without an RMA number clearly printed on the outside of the shipping container will be returned to sender. In order to receive full credit for signal boosters, all accessories originally included in the signal booster box must be returned with the signal booster. (The Buyer does not need to include accessories sold in addition to the signal booster, such as antennas or cables.)

This warranty does not apply to any product determined by SureCall to have been subjected to misuse, abuse, neglect, or mishandling that alters or damages the product's physical or electronic properties.

SureCall warrants to the Buyer that each of its products, when shipped, will be free from defects in material and workmanship, and will perform in full accordance with applicable specifications. The limit of liability under this warranty is, at SureCall's option, to repair or replace any product or part thereof which was purchased up to THREE YEARS after May 1, 2014 or TWO YEARS for products purchased before May 1, 2014, as determined by examination by SureCall, prove defective in material and/or workmanship. Warranty returns must first be authorized in writing by SureCall. Disassembly of any SureCall product by anyone other than an authorized representative of SureCall voids this warranty in its entirety. SureCall reserves the right to make changes in any of its products without incurring any obligation to make the same changes on previously delivered products.

As a condition to the warranties provided for herein, the Buyer will prepay the shipping charges for all products returned to SureCall for repair, and SureCall will pay the return shipping with the exception of products returned from outside the United States, in which case the Buyer will pay the shipping charges.

The Buyer will pay the cost of inspecting and testing any goods returned under the warranty or otherwise, which are found to meet the applicable specifications or which are not defective or not covered by this warranty.

Products sold by SureCall shall not be considered defective or non-conforming to the Buyer's order if they satisfactorily fulfill the performance requirements that were published in the product specification literature, or in accordance with samples provided by SureCall. This warranty shall not apply to any products or parts thereof which have been subject to accident, negligence, alteration, abuse, or misuse. SureCall makes no warranty whatsoever in respect to accessories or parts not supplied by it.

**Limitations of Warranty, Damages and Liability:**

EXCEPT AS EXPRESSLY SET FORTH HEREIN, THERE ARE NO WARRANTIES, CONDITIONS, GUARANTEES, OR REPRESENTATIONS AS TO MERCHANTABILITY, FITNESS FOR A PARTICULAR PURPOSE, OR OTHER WARRANTIES, CONDITIONS, GUARANTEES, OR REPRESENTATIONS, WHETHER EXPRESSED OR IMPLIED, IN LAW OR IN FACT, ORAL OR IN WRITING.

SURECALL AGGREGATE LIABILITY IN DAMAGES OR OTHERWISE SHALL NOT EXCEED THE PAYMENT, IF ANY, RECEIVED BY CELLPHONE-MATE, INC. FOR THE UNIT OF PRODUCT OR SERVICE FURNISHED OR TO BE FURNISHED, AS THE CASE MAY BE, WHICH IS THE SUBJECT OF CLAIM OR DISPUTE. IN NO EVENT SHALL SURECALL BE LIABLE FOR INCIDENTAL, CONSEQUENTIAL, OR SPECIAL DAMAGES, HOWSOEVER CAUSED.

All matters regarding this warranty shall be interpreted in accordance with the laws of the State of California, and any controversy that cannot be settled directly shall be settled by arbitration in California in accordance with the rules then prevailing of the American Arbitration Association, and judgment upon the award rendered may be entered in any court having jurisdiction thereof. If one or more provisions provided herein are held to be invalid or unenforceable under applicable law, then such provision shall be ineffective and excluded to the extent of such invalidity or unenforceability without affecting in any way the remaining provisions hereof.

SureCall has made a good faith effort to ensure the accuracy of the information in this document and disclaims the implied warranties of merchantability and fitness for a particular purpose and makes no express warranties, except as may be stated in its written agreement with and for its customers. SureCall shall not be held liable to anyone for any indirect, special or consequential damages due to omissions or errors. The information and specifications in this document are subject to change without notice.

© 2020. All Rights Reserved. All trademarks and registered trademarks are the property of their respective owners.

48346 Milmont Drive  
Fremont, California 94538, USA  
888.365.6283  
[www.surecall.com](http://www.surecall.com)