

FusionProfessional

Cellular signal booster kit for the Home or Office

User Guide



Introduction

Thank you for purchasing SureCall's Fusion Professional cellular signal booster kit. SureCall's Fusion Professional was specifically designed to eliminate frustrations over dropped calls and limited range by amplifying incoming and outgoing cellular signals in homes and offices.

If you have any questions during setup, please reach out to our US-based experienced support technicians:

Call: 1-888-365-6283

Email: support@surecall.com

Visit: www.surecall.com/support



Watch installation, optimization and troubleshooting techniques on our SureCall YouTube channel



[@SureCall](https://twitter.com/SureCall)



Stay up to date with all things SureCall

TABLE OF CONTENTS

- How it works 4
- PACKAGE CONTENTS..... 4
- BEFORE INSTALLATION..... 6
 - Installation Overview 6
- INSTALLATION 6
 - Step 1. Find the Area With the Strongest Signal..... 6
 - Step 2. Install the Outside Antenna..... 7
 - Step 3. Install the Booster and Inside Antenna 8
 - Step 4: Connect to Power and Turn On 9
 - Check and Optimize System, if Needed 10
- TROUBLESHOOTING 10
- LED INDICATORS..... 11
 - Antenna Isolation 11
- SPECIFICATIONS..... 12
 - Kitting 13
- CONSUMER GUIDELINES..... 14
- WARRANTY 15
 - Three-Year Product Warranty 15

How it works

1. An outside antenna collects signal from the cell tower.
2. The antenna sends the signal to the booster through coax cable.
3. The booster amplifies the cell signal and rebroadcasts the signal indoors via the inside antenna to all mobile devices within range.
4. The system also works in reverse amplifying outgoing signal back to the tower.

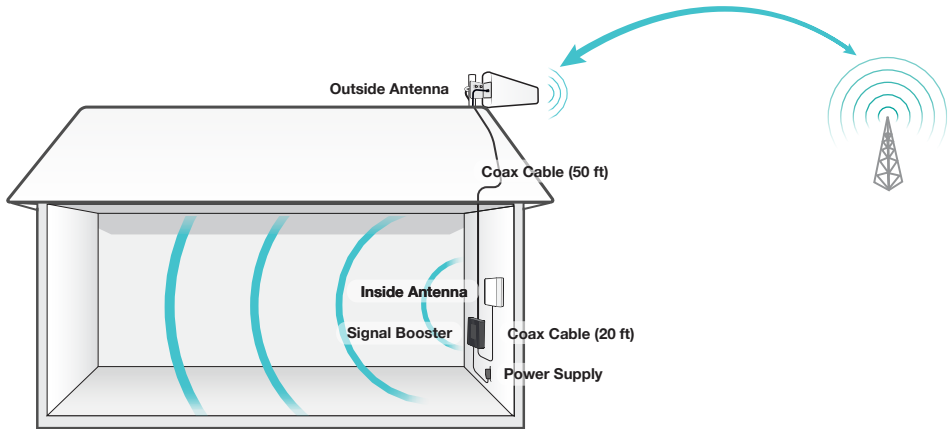

How the SureCall Fusion Professional Booster Works

PACKAGE CONTENTS

Unpack all package contents. For missing or damaged items, contact your reseller.

Turn over the signal booster and record the model and serial number for reference:

Serial #: _____

Purchase Date: _____

Keep the carton and packing material to store the product in case you need to return.

Your Fusion Professional signal booster package includes the following items:

1. SureCall FusionPro signal booster and power supply
2. Outside Yagi Antenna - SC-230W
3. Outside cable (50 ft) to connect the booster and outside antenna SC-400
4. Inside panel antenna -SC-248W
5. Inside cable (20 ft) to connect the booster and inside antenna - SC-240

1. Fusion Professional Booster and power supply



2. Outside Antenna: Directional Yagi Antenna



3. Outside Cable (50 ft)



4. Inside Antenna: Directional Panel Antenna



5. Inside Cable (20 ft)



Warning: Changes or modifications not expressly approved by SureCall could void the user's authority to operate the equipment.

FCC 15.105 Statement This equipment has been tested and found to comply with the limits for a Class B digital device, pursuant to part 15 of the FCC Rules. These limits are designed to provide reasonable protection against harmful interference in a residential installation. This equipment generates, uses and can radiate radio frequency energy and, if not installed and used in accordance with the instructions, may cause harmful interference to radio communications. However, there is no guarantee that interference will not occur in a particular installation. If this equipment does cause harmful interference to radio or television reception, which can be determined by turning the equipment off and on, the user is encouraged to try to correct the interference by one or more of the following measures:

- Reorient or relocate the receiving antenna
- Increase the separation between the equipment and receiver.
- Connect the equipment into an outlet on a circuit different from that to which the receiver is connected
- Consult the dealer or an experienced radio/TV technician for help.

BEFORE INSTALLATION

1. Prior to securing the location of any booster parts, a “soft install” is recommended as adjustments may be needed to optimize performance.
2. Ensure adequate separation between the planned locations of the inside and outside antenna – at least 25 ft (see diagram “Antenna Separation” on page 7).
3. For kits that use directional antennas (outside or inside), the directional antenna(s) should be oriented in a way that they do not “face” the other antenna (see “Aiming Directional Antennas” Diagram).
4. Ensure sufficient cable length between the outside antenna location and booster location. The length of the provided cable is 50 ft.

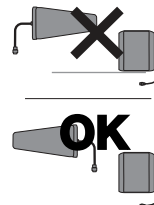

Aiming Directional Antennas

Installation Overview

Step 1. Find the outside area with the strongest signal.

Step 2. Install the outside antenna identified in step 1.

Step 3. Install the Inside antenna and booster.

Step 4. Connect power source and turn on.

Check System and Optimize Installation, if Needed

INSTALLATION

Step 1. Find the Area With the Strongest Signal

Using your phone, identify the outside location with the strongest signal for placement of your outside antenna. Generally, this is found above the roofline on the side facing your nearest cell tower and as high as possible – where the antenna can ‘see’ your cell tower. To find the location of your carrier’s closest cell tower, go to www.antennasearch.com.

The coverage area that the booster provides is directly related to the strength of incoming signal received by the outdoor antenna. Mounting the outside antenna where the signal is the strongest will provide the best results.

Please note, if signal is extremely weak where the outside antenna is installed, indoor coverage will be limited. Bars are not always a reliable measure of signal. The best way to confirm signal coverage is the ability to place and hold a call.

Putting your phone in Field Test mode will also indicate what level of decibels (dB) your phone is currently receiving. Decibels are measured in the negatives, and a score closer to zero indicates you have a better signal. A signal of -120 dB indicates you have no service, while a score of about -50 dB means you have excellent signal strength

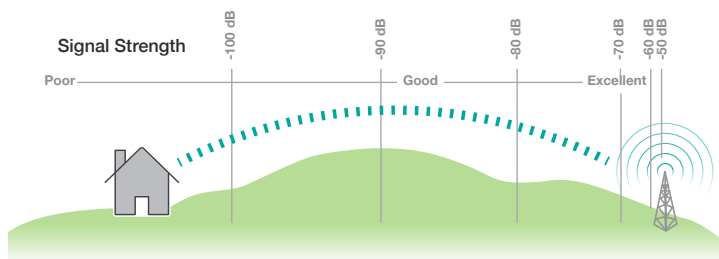

For specific dB signal measurements, use the methods below.

- Apple iPhones: Dial *3001#12345#* and press Call. In the top-left corner, a dB number appears instead of bars.
- Android devices: download the app “Network Signal Info” in the Google Play store.

Step 2. Install the Outside Antenna

After identifying the area of strongest signal, choose the surface where you will mount your outside antenna.

The location should allow for sufficient separation between the outside antenna and inside antenna. Vertical separation is preferred as it is more effective than horizontal separation.

The minimum separating distance recommended is 25 vertical feet; however, increased separation, up to 40 - 50 ft, may be needed, especially where vertical separation cannot be achieved.

Outside Yagi Antenna

Before installing a Yagi, or directional antenna, note that the antenna should be mounted on a pole or pipe (not provided), at the highest possible location above the roofline – at least 25 ft above the indoor antenna – aimed in the direction of your nearest cell tower. To find the location of your carrier’s closest cell tower, go to www.antennasearch.com.

Ensure that the mounting area has at least a 3 ft radius clear of obstructions, other radiating elements and metal objects such as pipes or metal siding and orient the antenna with the drip hole at the bottom.

Once you have identified your install location, assemble the u-bolt, bracket, nuts and washers onto a pole (available separately) as shown in the illustration. Keep the connections loose enough to allow the antenna to rotate until the optimum direction is found.

Once the outside antenna is secured to a pipe or pole, connect antenna to one end of the provided SC-400 cable and tighten the connection. Run the cable along route to planned location of your booster.

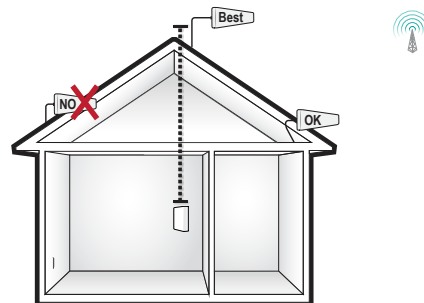

Antenna Separation

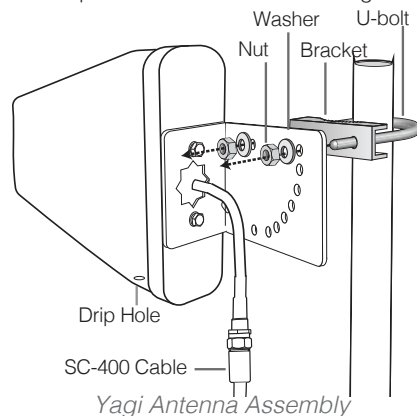

Yagi Antenna Assembly

Warning: Do not collocate antennas or operate the outdoor antenna with any other antenna or signal booster.

Step 3. Install the Booster and Inside Antenna

Choose a location for the booster and inside antenna that is near a working outlet and at least 25 Ft from the outside antenna. Consider the below factors affecting booster performance.

1. Signal strength at the location of the outside antenna.
2. Interior building materials between the inside antenna and your mobile device.
3. Distance between the outside antenna and inside antenna (minimum 25 ft. separation).

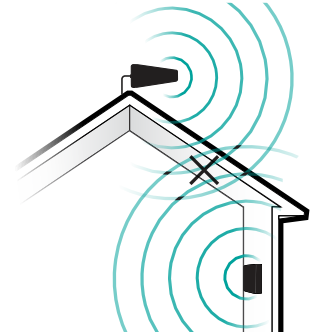

Aiming Antennas

Caution: Do Not aim antennas towards one another.

Panel Antenna

SureCall's Inside panel antennas are directional with a 120° reach. They should be mounted facing the area signal is needed and away from the outdoor antenna (See "Aiming Antennas").



Panel Antenna

Mount on a vertical surface that is the approximate height of normal cell phone use. The antenna may be concealed behind a wall provided there are no materials that could obstruct signals.

Besides the antenna itself, parts include mounting equipment for a flat horizontal surface.

1. Using plate, mark position of desired screw placement.
 2. Screw mounting plate into place with the slide panel protruding towards you.
 3. Slide antenna securely onto mounting plate.
4. Connect antenna to one end of the SC-240 cable and run to planned location of your booster
 5. Place the booster on a flat surface or mounted to a wall and connect the remaining end of the SC-240 cable to booster port marked INSIDE.

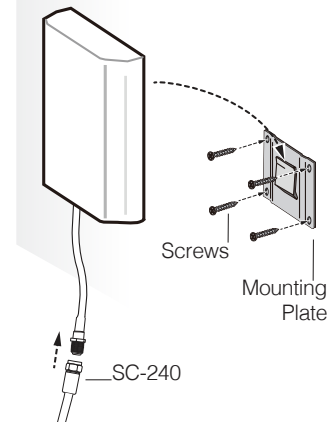

Place the Booster

To install the booster to a wall, select a location that is near a working AC outlet. Use the supplied screws or appropriate screws for surface of mounting location and drill through screw tab holes on booster (see “Booster Diagram” illustration) and mount the booster to a wall.

Next, connect the outside antenna and booster by connecting the open end of the 50 ft. cable leading from the outside antenna to the port of the booster marked “OUTSIDE”.

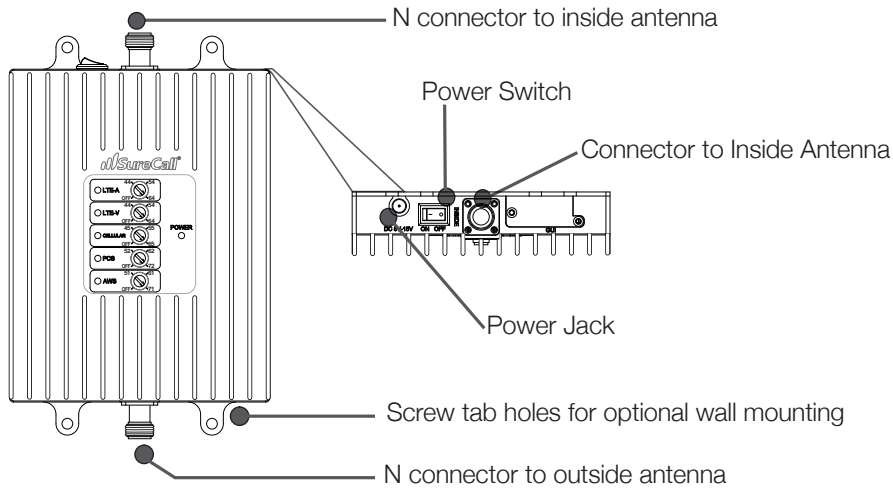

Booster Diagram

Step 4: Connect to Power and Turn On

Connect the AC power cord to the booster and plug into a 110V AC power outlet. Once the booster has been completely assembled, turn the booster’s power switch to ON.

Note: If the Power LED does not turn ON, see the “Troubleshooting” on page 12 .

Note: This booster is rated for 5-15V input voltage. DO NOT use the booster with a higher voltage power supply. This can damage the booster, cause personal injury, and void your warranty.

This booster should not be used near open fire or flame. Storage and transportation: Store and place in non-extreme room-temperature and dry environment.

Check and Optimize System, if Needed

Place a call and walk throughout your space to confirm that your phone is receiving a boosted signal.

If indoor coverage is limited, consider the following factors:

1. Signal strength at the location of the outside antenna. Coverage area is directly related to the strength of incoming signal received by the outdoor antenna. If signal is weak where the outside antenna is installed, indoor coverage will be limited.
2. Interior building materials between the inside antenna and your mobile device.
3. Separation between the outside antenna and inside antennas (minimum 25 ft. of vertical separation).
 - Inadequate separation will be indicated by the LEDs on your booster after start up. See “LED Indicators” on page 11 for more information.
 - Adjustments, if indicated by LEDs, are likely resolved by improving antenna separation. See “Antenna Isolation” on page 11
 - The booster gain dials should remain at maximum level and only reduced if other recommended actions do not resolve the issue.

WARNING: Do not attenuate the uplink and downlink dB settings below 35dB. This could cause the affected frequency band to turn off.

LED INDICATORS

The gain dials on the booster should always be at maximum level unless a control light is flashing red-yellow. Additionally, they should only be reduced if other recommended actions do not resolve the issue.

Condition	Indication/Status	Indication/Resolution
Initializing on Power-up		All control lights flash RED & YELLOW for 5 seconds then off for 5 minutes.
GREEN SOLID	Normal Operation	
GREEN FLASHING	Normal Operation	Automatic Gain Control (AGC) is self-adjusting.
YELLOW SOLID	Normal Operation, Sleep Mode	After a period of inactivity, the band will enter sleep mode <i>After 5 minutes the frequency control light will return to SOLID GREEN.</i>
YELLOW FLASHING Slowly	Minor gain reduction (1 - 10 dB)	AGC has detected Insufficient separation between the inside and outside antenna automatically reduced gain by 1 - 10 dB for the indicated frequency band. This may be unavoidable in some situations where distance cannot be achieved. <i>After 5 minutes the frequency control light will return to SOLID GREEN.</i>
YELLOW FLASHING Quickly	Significant gain reduction (10 - 20 dB)	AGC has detected significant antenna isolation issues causing a reduction in gain between 10 -- 20 dB for the indicated frequency band. This significant reduction in booster performance is a result of inadequate isolation between the inside and outside antenna. Adjustments should be made to improve your booster's performance by following suggested methods below. <i>After 5 minutes the frequency control light will return to SOLID GREEN.</i>
RED / YELLOW FLASHING Alternately	Extreme gain reduction (>20 dB) The frequency band has been disabled	AGC has detected significant antenna isolation issues causing a reduction in gain greater than 20 dB for the indicated frequency band. The control light will continue to RED-YELLOW until antenna separation is increased or the Frequency is manually turned-off by the control knob Follow the suggestions below to isolate antenna antennas. If, after following the recommendations to isolate antennas, the RED / YELLOW LED persists, locate the dials for the affected frequency bands and, in small increments, lower the gain until the status is resolved.
RED SOLID	Indicates the frequency band is manually turned off	A SOLID RED Control light means the frequency has been manually turned off. While the Frequency gain control knobs should be left to maximum gain as a general rule, in unique situations, you can manually disable a frequency by turning the gain control to OFF.

Antenna Isolation

The Fusion Professional automatically reduces gain (coverage performance) because of insufficient RF Separation between the inside and outside antennas.

Review strategies to improve RF isolation between the inside and outside antennas. Note, in smaller wood constructed homes some reduction in gain (slow YELLOW flash) is considered 'normal' operation.

Specifications

Consider the following options to resolve issues with inadequate antenna isolation.

1. Verify that a minimum distance of 25 vertical feet has been achieved. Separation up to 40 - 50 ft may be needed, however, especially where vertical separation is not possible.
2. Check for sources of interference such as, cellular modems or hotspots.
3. Verify neither antenna is placed near a window.
4. Ensure that the antennas are aimed away from one another.

Keep in mind, identifying the setup that yields the best possible results for your environment will come from testing -- balancing the elimination of interference and while also receiving the best possible signal.

TROUBLESHOOTING

If you have any questions during setup, please contact our US-based support technicians:

Call: 1-888-365-6283 | Email: support@surecall.com | Visit: www.surecall.com/support

Problem	Resolution
Signal booster has no power	Connect the power supply to an alternate power source. Verify that the power source is not controlled by a switch that has removed power from the outlet. If it remains OFF, contact tech support at: 1-888-365-6283 or support@surecall.com
After completing installation, indoor signal coverage has not improved	Verify that cable connections are tightly fitted to the booster and antennas. Try further separating the booster and antenna. Verify that there is usable signal where the antenna is placed. Note: Bars are not always a reliable measure of signal. The best way to confirm signal coverage is the ability to place and hold a call.

Kitting

Component	Product number	Gain/Loss					Note
		LTE-A 707 MHz	LTE-V 731 MHz	Cellular 800 MHz	PCS 1900 MHz	AWS 1700 / 2100 MHz	
Outdoor Antenna*	SC-288W / SC-289W	3 dBi	3 dBi	3 dBi	4 dBi	4 dBi / 4 dBi	
	SC-230W / SC-231W	7 dBi	7 dBi	8 dBi	10 dBi	10 dBi / 10 dBi	
Outdoor Cable*	SC-400 (50')	3.01 dB	3.01 dB	3.14 dB	4.31 dB	4.07 dB / 4.56 dB	50 Feet or longer
Inside Cable*	SC-240 (20')	2.06 dB	2.06 dB	2.29 dB	3.56 dB	3.36 dB / 3.76 dB	20 Feet or longer
Inside Antenna*	SC-248W	7 dBi	7 dBi	7 dBi	10 dBi	10 dBi / 10 dBi	
	SC-222W	3 dBi	3 dBi	3 dBi	6 dBi	6 dBi / 6 dBi	
	SC-121W	1.2 dBi	1.2 dBi	1.2 dBi	3 dBi	3 dBi / 3 dBi	
	SC-302W	2.5 dBi	2.5 dBi	3 dBi	5 dBi	4 dBi / 5 dBi	

Warning: Any product modifications that use unauthorized antennas, cables, and/or coupling devices are prohibited by the FCC. Contact FCC for details: 1-888-CALL-FCC. Changes or modifications not expressly approved by SureCall could void the user's authority to operate the equipment.

FCC 27.50(d)(4) Statement: Fixed, mobile and portable (hand-held) stations operating in the 1720-1755 MHz band are limited 1 Watt EIRP. Fixed stations operating in this band are limited to a maximum antenna height of 10 meters above ground. Mobile and portable stations operating in this band must employ a means for limiting power to the minimum necessary for successful communications.

15.19 This device complies with Part 15 of the FCC Rules. Operation is subject to the following two conditions: (1) this device may not cause harmful interference, and (2) this device must accept any interference received, including interference that may cause undesired operation.

SPECIFICATIONS

Model	Fusion Professional
Uplink Frequency Range (MHz):	698-716 / 776-787 / 824-849 / 1850-1915 / 1710-1755
Downlink Frequency Range (MHz):	728-746 / 746-757 / 869-894 / 1930-1995 / 2110-2155
Maximum Gain:	72 dB
Supported Standards:	CDMA, WCDMA, GSM, EDGE, HSPA+, EVDO, LTE and all cellular standards
Max Uplink Power:	26.0 dBm
Input Impedance:	50Ω donor port / 50Ω server port
Noise Figure:	8 dB
AC Input:	Input AC110V, 60 Hz; Output DC 5-15V
Maximum Output Power:	1 Watt EIRP
Cable:	SC-400 / SC-240
RF Connectors:	N Female (outdoor) / N Female (indoor)
Power Consumption:	<15W
Operation Temperature:	-4° to +158° F
Dimensions:	7.875 x 5 x 1.188 inches
Weight:	2 LB 3 oz
Certifications:	FCC ID: RSNF4HOME3, IC: 7784A-F4HOME3

PreAGC						
Frequency (MHz)	Pulse GSM			4.1 MHz AWGN		
	Input (dBm)	Output (dBm)	Gain (dB)	Input (dBm)	Output (dBm)	Gain (dB)
Uplink: 1710-1755	-43.4	24.4	67.8	-47.1	20.7	67.8
Uplink: 1850-1915	-43.8	25.1	68.9	-47.0	21.0	68.0
Uplink: 824-849	-37.9	25.6	63.5	-38.5	24.5	63.0
Uplink: 698-716	-36.9	25.4	62.3	-37.1	23.8	60.9
Uplink: 777-787	-36.5	25.1	61.6	-36.3	25.2	61.5
Downlink: 2110-2155	-59.4	9.3	68.7	-60.4	8.0	68.4
Downlink: 1930-1995	-60.4	9.5	69.9	-61.7	8.0	69.7
Downlink: 869-894	-50.5	11.2	61.7	-51.6	9.9	61.5
Downlink: 728-746	-50.5	11.1	61.6	-52.2	8.8	61.0
Downlink: 746-757	-51.0	10.2	61.2	-52.3	8.1	60.4

CONSUMER GUIDELINES

This is a CONSUMER device

BEFORE USE, you **MUST REGISTER THIS DEVICE** with your wireless provider and have your provider's consent. Most wireless providers consent to the use of signal boosters. Some providers may not consent to the use of this device on their network. If you are unsure, contact your provider.

In Canada, **BEFORE USE** you must meet all requirements set out in ISED [CPC-2-1-05](#)¹

You **MUST** operate this device with approved antennas and cables as specified by the manufacturer. Antennas **MUST** be installed at least 20 cm (8 inches) from (i.e. **MUST NOT** be installed within 20 cm of) any person.

You **MUST** cease operation of this device immediately if requested by the FCC (or ISED in Canada) or a licensed wireless service provider.

WARNING: E911 location information may not be provided or may be inaccurate for calls served by using this device.

This device may be operated **ONLY** in a fixed location, for in-building use.

Ce produit est un appareil de CONSOMMATION

AVANT DE L'UTILISER, vous **DEVEZ ENREGISTRER CE DISPOSITIF** auprès de votre fournisseur de services cellulaires et obtenir son consentement. La plupart des fournisseurs de services cellulaires autorisent l'utilisation d'amplificateurs de signal. Il se peut que certains fournisseurs n'autorisent pas l'utilisation de ce dispositif sur leur réseau. Si vous n'êtes pas sûr, contactez-le.

Au Canada, **AVANT DE L'UTILISER** vous devez répondre à toutes les exigences ISED [CPC-2-1-05](#)²

Vous **DEVEZ** utiliser ce dispositif avec les antennes et les câbles autorisés, tel que le spécifie le fabricant. Les antennes **DOIVENT** être installées à au moins 20 cm (8 po) (**NE DOIVENT PAS** être installées à moins de 20 cm) de toute personne avoisinante.

Vous **DEVEZ** arrêter cet appareil immédiatement à la demande de la FCC (ISED au Canada) ou de tout fournisseur de services cellulaires autorisé.

AVERTISSEMENT: Il se peut que les informations relatives à la localisation E911 ne soient pas disponibles ou soient inexactes pour les appels qui utilisent cet appareil.

Cet appareil peut fonctionner seulement à un emplacement fixe à l'intérieur d'un bâtiment;

Register your cellular booster with your wireless carrier at the following urls:

Verizon: <http://www.verizonwireless.com/wcms/consumer/register-signal-booster.html>

AT&T: <https://securec45.securewebsession.com/attsignalbooster.com/>

T-Mobile: <https://support.t-mobile.com/docs/DOC-9827>

Sprint: https://www.sprint.com/legal/fcc_boosters.html

U.S. Cellular: <http://www.uscellular.com/uscellular/support/fcc-booster-registration.jsp>

CAN ICES-3 (B)/NMB-3(B) (Canada) :

This Class B digital apparatus meets all requirements of the Canadian Interference Causing Equipment Regulations. Operation is subject to the following two conditions: (1) this device may not cause harmful interference, and (2) this device must accept any interference received, including interference that may cause undesired operation

The Manufacturer's rated output power of this equipment is for single carrier operation. For situations when multiple carrier signals are present, the rating would have to be reduced by 3.5 dB, especially where the output signal is re-radiated and can cause interference to adjacent band users. This power reduction is to be by means of input power or gain reduction and not by an attenuator at the output of the device.

Cet appareillage numérique de la classe B répond à toutes les exigences de l'interférence canadienne causant des règlements d'équipement. L'opération est sujette aux deux conditions suivantes: (1) ce dispositif peut ne pas causer l'interférence nocive, et (2) ce dispositif doit accepter n'importe quelle interférence reçue, y compris l'interférence qui peut causer l'opération peu désirée.

La puissance de sortie nominale indiquée par le fabricant pour cet appareil concerne son fonctionnement avec porteuse unique. Pour des appareils avec porteuses multiples, on doit réduire la valeur nominale de 3,5 dB, surtout si le signal de sortie est retransmis et qu'il peut causer du brouillage aux utilisateurs de bandes adjacentes. Une telle réduction doit porter sur la puissance d'entrée ou sur le gain, et ne doit pas se faire au moyen d'un atténuateur raccordé à la sortie du dispositif.

1 For details on the requirements specified in ISED CPC-2-1-05, visit: <http://www.ic.gc.ca/eic/site/smt-gst.nsf/eng/sf08942.html>

2 Pour plus de détails sur les exigences ISED CPC-2-1-05, reportez-vous au site: <http://www.ic.gc.ca/eic/site/smt-gst.nsf/eng/sf08942.html>

WARRANTY

Three-Year Product Warranty

To activate your three-year manufacturer's warranty, register at www.SureCall.com/activate

SureCall warrants its products for three years from the date of purchase against defects in workmanship and/or materials. Specifications are subject to change. The three-year warranty only applies to products meeting the latest FCC Certification Guidelines stated on 2/20/2013 and going into effect April 30, 2014. A two-year warranty applies to any products manufactured before May 1, 2014.

Products returned by customers must be in their original, un-modified condition, shipped in the original or protective packaging with proof-of-purchase documentation enclosed, and a Return Merchandise Authorization (RMA) number printed clearly on the outside of the shipping container.

Buyers may obtain an RMA number for warranty returns by calling the SureCall Return Department toll-free at 1-888-365-6283. Any returns received by SureCall without an RMA number clearly printed on the outside of the shipping container will be returned to sender. In order to receive full credit for signal boosters, all accessories originally included in the signal booster box must be returned with the signal booster. (The Buyer does not need to include accessories sold in addition to the signal booster, such as antennas or cables.)

This warranty does not apply to any product determined by SureCall to have been subjected to misuse, abuse, neglect, or mishandling that alters or damages the product's physical or electronic properties.

SureCall warrants to the Buyer that each of its products, when shipped, will be free from defects in material and workmanship, and will perform in full accordance with applicable specifications. The limit of liability under this warranty is, at SureCall's option, to repair or replace any product or part thereof which was purchased up to THREE YEARS after May 1, 2014 or TWO YEARS for products purchased before May 1, 2014, as determined by examination by SureCall, prove defective in material and/or workmanship. Warranty returns must first be authorized in writing by SureCall. Disassembly of any SureCall product by anyone other than an authorized representative of SureCall voids this warranty in its entirety. SureCall reserves the right to make changes in any of its products without incurring any obligation to make the same changes on previously delivered products.

As a condition to the warranties provided for herein, the Buyer will prepay the shipping charges for all products returned to SureCall for repair, and SureCall will pay the return shipping with the exception of products returned from outside the United States, in which case the Buyer will pay the shipping charges.

The Buyer will pay the cost of inspecting and testing any goods returned under the warranty or otherwise, which are found to meet the applicable specifications or which are not defective or not covered by this warranty.

Products sold by SureCall shall not be considered defective or non-conforming to the Buyer's order if they satisfactorily fulfill the performance requirements that were published in the product specification literature, or in accordance with samples provided by SureCall. This warranty shall not apply to any products or parts thereof which have been subject to accident, negligence, alteration, abuse, or misuse. SureCall makes no warranty whatsoever in respect to accessories or parts not supplied by it.

Limitations of Warranty, Damages and Liability:

EXCEPT AS EXPRESSLY SET FORTH HEREIN, THERE ARE NO WARRANTIES, CONDITIONS, GUARANTEES, OR REPRESENTATIONS AS TO MERCHANTABILITY, FITNESS FOR A PARTICULAR PURPOSE, OR OTHER WARRANTIES, CONDITIONS, GUARANTEES, OR REPRESENTATIONS, WHETHER EXPRESSED OR IMPLIED, IN LAW OR IN FACT, ORAL OR IN WRITING.

SURECALL AGGREGATE LIABILITY IN DAMAGES OR OTHERWISE SHALL NOT EXCEED THE PAYMENT, IF ANY, RECEIVED BY CELLPHONE-MATE, INC. FOR THE UNIT OF PRODUCT OR SERVICE FURNISHED OR TO BE FURNISHED, AS THE CASE MAY BE, WHICH IS THE SUBJECT OF CLAIM OR DISPUTE. IN NO EVENT SHALL SURECALL BE LIABLE FOR INCIDENTAL, CONSEQUENTIAL, OR SPECIAL DAMAGES, HOWSOEVER CAUSED.

All matters regarding this warranty shall be interpreted in accordance with the laws of the State of California, and any controversy that cannot be settled directly shall be settled by arbitration in California in accordance with the rules then prevailing of the American Arbitration Association, and judgment upon the award rendered may be entered in any court having jurisdiction thereof. If one or more provisions provided herein are held to be invalid or unenforceable under applicable law, then such provision shall be ineffective and excluded to the extent of such invalidity or unenforceability without affecting in any way the remaining provisions hereof.

SureCall has made a good faith effort to ensure the accuracy of the information in this document and disclaims the implied warranties of merchantability and fitness for a particular purpose and makes no express warranties, except as may be stated in its written agreement with and for its customers. SureCall shall not be held liable to anyone for any indirect, special or consequential damages due to omissions or errors. The information and specifications in this document are subject to change without notice.

© 2020. All Rights Reserved. All trademarks and registered trademarks are the property of their respective owners.

SureCall, Inc
48346 Milmont Drive
Fremont, California 94538, USA
888.365.6283 | www.surecall.com